

INSTRUCTIONS

FP150 FOOD PROCESSOR

MODEL *FP150* *ML-104600*



701 S. RIDGE AVENUE
TROY, OHIO 45374-0001

937 332-3000

www.hobartcorp.com

F-33530 Rev B (August 2008)

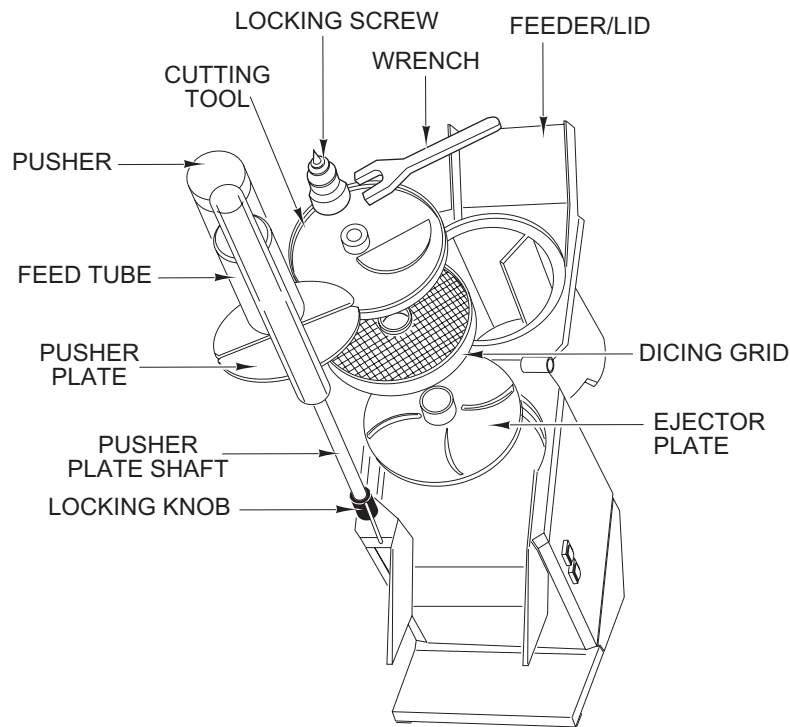

FP150 Food Processor

TABLE OF CONTENTS

GENERAL	3
INSTALLATION	3
Unpacking	3
Location	3
Electrical Connections	3
OPERATION.....	3
Controls.....	4
Operations With A Single Plate — (Fig. 1) (Slicing, Shredding, Grating And Julienne Cutting).....	4
Operations With Two Plates — (Fig. 2) (Dicing)	4
Cutting Tool Guide.....	5
Using the Feed Hopper.....	6
Using the Feed Tube.....	6
CLEANING	6
MAINTENANCE	7
Replacement Dicing Grids	7
TROUBLESHOOTING	8
Service	8

Installation, Operation and Care of MODEL FP150 FOOD PROCESSOR

SAVE THESE INSTRUCTIONS

GENERAL

The Model FP150 Food Processor is used for slicing, shredding, grating, Julienne cutting and dicing vegetables, fruits or cheese. The compact unit is designed for ease of operation and quick cleaning. A wall rack and a wide range of slicer, shredder, and dicing plates are available options.

INSTALLATION

UNPACKING

Prior to installation, test the electrical service to ensure that it agrees with the specifications on the data plate located at the rear. Immediately after unpacking the FP150, check for possible shipping damage. If the food processor is found to be damaged, save the packaging material and contact the carrier within 15 days of delivery. Do not lift the food processor with any hinged or extended parts; lift only with one hand under the protruding lip at the rear near the base of the motor compartment and the other hand underneath the chute.

LOCATION

The FP150 should be operated on a suitable counter height surface. A pan (not provided), suitable for kitchen use, can be used to capture the product at the exit chute.

ELECTRICAL CONNECTIONS

⚠ WARNING The electrical cord on this machine is equipped with a grounding- type plug which must be connected to a properly grounded receptacle. If the receptacle is not the proper grounding type, contact an electrician. Do not remove the grounding prong from the plug.

OPERATION

⚠ WARNING Rotating knives inside. Always use pusher plate. Keep hands out.

Proper assembly of the FP150, including selection of the appropriate cutters, is necessary for correct operation of the food processor (Fig's. 1 & 2). Refer to the Cutting Tool Guide for sizes of cutters and refer to the appropriate operation instructions.

CONTROLS

START (Green) — Push to start.

STOP (Red) — Push to stop.

Interlock switches prevent the machine from operating when the feed hopper is out of position or the pusher plate is raised above the feed hopper. If these features do not function as described, contact your local Hobart service office.

During operation, when the pusher plate is fully raised above the feed hopper, the machine stops and allows the pusher plate to be rotated counterclockwise for loading. To continue operation, rotate the pusher plate clockwise until it is directly above the feed hopper. As the pusher plate begins to lower into the hopper, the machine will restart — you do not need to push the green START switch unless STOP was pressed.

Always push the red STOP switch before changing cutters or cleaning.

OPERATIONS WITH A SINGLE PLATE — (FIG. 1) (SLICING, SHREDDING, GRATING AND JULIENNE CUTTING)

1. Grasp pistol grip handle, raise pusher plate and turn to the left.
2. Release the feed hopper lock by turning the finger paddle counterclockwise. Then raise the feed hopper.
3. Remove the locking screw by turning it clockwise. Always use the wrench when removing the locking screw.
4. Lower the ejector plate on the knife shaft until the ejector plate seats on the shaft pin.
5. Select the appropriate plate for the job. Place the plate on the shaft, turning until engaged. Lock the cutting tool by turning the locking screw counterclockwise. **THE LOCKING SCREW MUST ALWAYS BE USED.**
6. Lower the feed head. When the pusher plate is rotated and lowered, the feed head will automatically be locked.

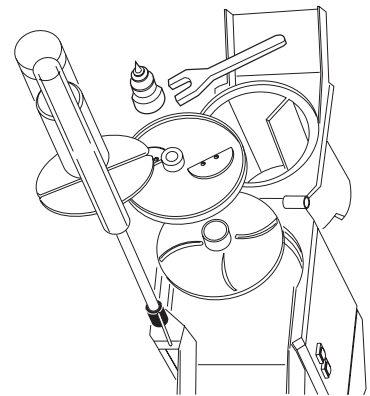

Fig. 1

OPERATIONS WITH TWO PLATES — (FIG. 2) (DICING)

1. Raise the pusher plate and turn it to the left.
2. Release the feed hopper lock by turning the finger paddle counterclockwise. Then raise the feed hopper.
3. Remove the locking screw by turning it clockwise. Always use the wrench when removing the locking screw.
4. Lower the ejector plate on the knife shaft until the ejector plate seats on the shaft pin.
5. Select the proper size dicing plate and place it correctly on the knife shaft above the ejector plate. Select the appropriate slicing plate for the job (see Cutting Tool Guide). Place the slicing plate on the shaft, turning until engaged. Lock the cutting tool by turning the locking screw counterclockwise. **THE LOCKING SCREW MUST ALWAYS BE USED.**
6. Lower the feed hopper. When the pusher plate is rotated and lowered, the feed hopper will automatically be locked.

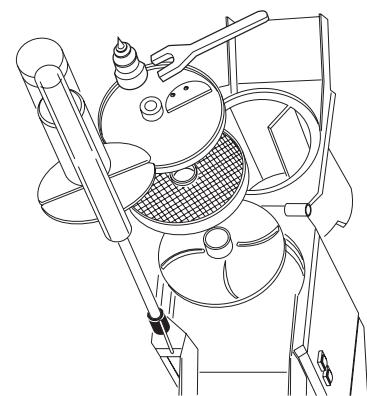
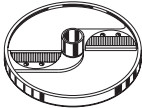

Fig. 2

CUTTING TOOL GUIDE



Crimping Slicer — $\frac{3}{16}$ " (4.5 MM)

For ripple slicing of root vegetables.

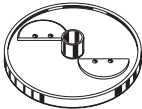

Fine Slicer (2 Blade) — $\frac{1}{16}$ " (1.5 MM)

For slicing firm or fragile products. Also for use with $\frac{9}{32}$ " dicing plate. Makes very thin slices of pepperoni, mushrooms, cabbage, potatoes, cucumbers and radishes.

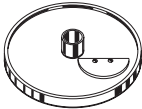

Fine Slicer (1 Blade) — $\frac{5}{32}$ " (4 MM), $\frac{9}{16}$ " (14 MM), $\frac{1}{8}$ " (3 MM), $\frac{7}{32}$ " (6 MM), $\frac{3}{8}$ " (10 MM)

Use is same as 2-blade fine slicer. Also slices soft and/or juicy products such as tomato, lemon and banana. Shreds lettuce. Dices in combination with $\frac{5}{32}$ " dicing grid. Chops onion in combination with $\frac{3}{8}$ " dicing grid.

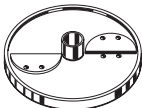

Julienne Cutter —

$\frac{3}{32}$ " (2MM) — Makes various salad toppings.

$\frac{3}{16}$ " (4.5MM) — Makes shoestring French fries.

$\frac{5}{16}$ " (8 MM) — Makes French fries.

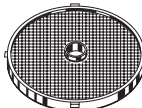

Dicing Grid — Dices in combination with dicing cutter or fine cut slicer. The dicer grid dimension must be equal to, or larger than, the slicer dimension.

$\frac{9}{32}$ " (7.5 MM) (use with $\frac{7}{32}$ " or smaller Slicer) — For thin diced vegetables (carrots, celery, onions, potatoes and vegetables for soup).

$\frac{3}{8}$ " (10 MM) (use with $\frac{3}{8}$ " or smaller Slicer) — Good for dicing firm chilled tomatoes.

$\frac{3}{4}$ " (20 MM) (use only with $\frac{9}{16}$ " Slicer) — Prepares tomatoes, potatoes for home fries or potato salad and dices apples or melon.

$\frac{5}{8}$ " (15 MM) (use with $\frac{3}{8}$ " or smaller Slicer) — Dices tomatoes, apples, melon and other fruits for salads, pies or other uses.



Grater — Fine

Makes grated Parmesan or Romano cheese (hard cheese only).



Shredder — Shredder plates are used to process cheese for toppings and salad bar items, cabbage for coleslaw, potatoes for hash browns or potato pancakes.

$\frac{1}{16}$ " (1.5 MM) — Makes extra fine shredded cheese for sandwich topping or other uses.

$\frac{3}{32}$ " (2 MM) — Makes fine breadcrumbs and cracker crumbs for use in cooking. Use when machine and product are dry.

$\frac{1}{8}$ " (3 MM) — Medium shredder for various uses.

$\frac{3}{16}$ " (4.5 MM) — Makes pizza toppings and salad bar items.

$\frac{5}{16}$ " (8 MM) — Shreds cabbage and soft pizza cheese.

$\frac{7}{32}$ " (6 MM) — Shreds carrot, dry bread, almonds, nuts, and soft pizza cheese.

A wall rack is available to hang the cutting tools for easy access of the operator and to protect sharpness of the blades.

USING THE FEED HOPPER

After the pusher plate is raised, prepared products such as potatoes, carrots, onions, lettuce, cabbage, etc., can be placed in the large feed hopper.

The feed hopper has one fixed and one detachable partition wall. For highest capacity and best cutting results, the detachable partition wall should be removed only when necessary because of product size. To remove the detachable partition wall, unscrew the two black knobs on the outside of the feed hopper. The fixed partition wall is used as support for round products such as lemons and tomatoes, when producing slices for a cross cut, or when you want best possible cutting results cutting potato chips (one stack only). For best results, it is advisable to remove tops and tails from products like lemons, limes or onions and place them in the hopper perpendicular to the desired cut.

When cutting French fries with the Julienne cutter, position the potatoes at the lower right corner of the large feed hopper. The potatoes may be stacked to cut several at one time. For consistent results, stack product in the lower right corner of the feed hopper, one pile only.

USING THE FEED TUBE

Twist the knob to release the catch on the feed tube pusher and pull out to expose the feed tube opening.

The feed tube is used for slicing long, thin-shaped products such as cucumbers or carrots, or to contain small items like radishes. The machine does not stop when the feed tube pusher is removed; this allows product to be processed continuously. Always use the feed tube pusher.

CLEANING

⚠ WARNING Turn the machine off and unplug the electrical cord before cleaning.

Clean the machine immediately after each use. Dismantle all removable parts from the machine and wash them in warm water and detergent. Rinse thoroughly and wipe dry with a soft clean cloth.

Allowing food juices to dry on the machine may cause discoloration. NEVER clean feed hopper, cutting tools or other aluminum parts in highly alkaline dishwashing solutions or in excessively hot water as this can cause formation of aluminum oxide (black). DO NOT use steel wool or sharp objects for cleaning machine surfaces if they become discolored; scratched surfaces become hard to keep clean.

1. Remove feed tube pusher and wash in warm water and detergent then rinse in lukewarm water. Raise the pusher plate and turn it to the left.
2. Remove the feed hopper and wash in warm water and detergent then rinse it in lukewarm water.
3. Remove the locking screw; always use the wrench.
4. Lift out the cutting plate. If you have used the dicing grid, push the remaining leftovers through the grid with the nylon brush before removing.
5. Remove dicing plate and ejector plate; wash in warm water and detergent then rinse in lukewarm water.
6. Turn the pusher plate back clockwise over the feed hopper and lower it.

7. Place a pan under the exit chute and pour lukewarm water from the top through the knife chamber. Run wet cloth through feed tube. Wipe with a clean dry cloth.
8. Return the cutting tools to the wall rack. Lower the ejector plate onto the knife shaft until the ejector plate seats on the shaft pin.
9. Replace the locking screw.
10. Place the feed hopper on the hinge pins and lower to normal position. Turn and lower the pusher plate. Replace the feed tube pusher.

MAINTENANCE

⚠ WARNING Turn the machine off and unplug the electrical cord before doing any maintenance.

Routinely inspect the machine to ensure that it is in proper working order. Plates must be clean, intact and sharp.

Regularly lubricate the pusher plate shaft with a drop of mineral oil, NOT COOKING OIL.

If the machine develops any problems, contact your local Hobart service office.

REPLACEMENT DICING GRIDS

Depending on usage, dicing grids become dull from wear with an average life expectancy from 8-18 months. Dicing grids cannot be resharpened and are therefore expendable. Replacement dicing grids are available from your local Hobart Service Office.

TROUBLESHOOTING

SYMPTOM	POSSIBLE CAUSE	SUGGESTED ACTION
Motor will not start.	Feed hopper not locked in correct position.	Make sure feed hopper is locked correctly.
	Pusher plate raised.	Turn pusher plate clockwise and lower it.
	Fuse or circuit breaker interrupting power.	Have electrician check circuit.
Machine stops while operating and will not restart.	Motor is overloaded and motor is too warm.	Allow the motor to cool; motor protector will allow restart when it has cooled.
	Pusher plate raised.	Turn pusher plate clockwise and lower it.
	Fuse or circuit breaker interrupting power.	Have electrician check circuit.
Low output or bad cutting results.	Wrong cutting plates used.	Refer to CUTTING TOOL GUIDE.
	Slicing, shredding, dicing, or Julienne cutting plate is NOT OK.	Make sure plates are intact and sharp.
	Feeding pressure excessive.	A light feeding pressure is best for most products.
Scraping sounds.	When dicing, dicing grid not all the way down to proper position.	Stop machine immediately. Remove dicing grid and clean side wall and ledge in cutting tool chamber.
	Locking screw not mounted.	Mount the locking screw.
Cutting tool locked to shaft.	Product built-up in machine.	Carefully rotate the cutting tool clockwise with a little force.

SERVICE

Contact your local Hobart Service Office for any repairs or adjustments needed on this equipment. Long-term service contracts are available on this and other Hobart products.