



TRUE FOOD SERVICE EQUIPMENT, INC.

2001 East Terra Lane • P.O. Box 970 • O'Fallon, Missouri 63366
 (636)240-2400 • Fax (636)272-2408 • (800)325-6152 • Intl Fax# (001)636-272-7546
 Parts Dept. (800)424-TRUE • Parts Dept. Fax# (636)272-9471 • www.truemfg.com

Project Name: _____

Location: _____

Item #: _____ Qty: _____

Model #: _____

A/A #

SIS #

Model:
GDM-49F

Glass Door Merchandiser:
 Freezer



GDM-49F

- ▶ The world's #1 manufacturer of glass door merchandisers.
 - ▶ Designed using the highest quality materials and components to provide the user with an attractive, point of purchase merchandiser that brilliantly displays frozen food and ice cream, resulting in high impulse sales.
 - ▶ Oversized, factory balanced, refrigeration system holds -10°F (-23.3°C). Ideal for ice cream and frozen food products.
 - ▶ Exterior - non-peel or chip white laminated vinyl; durable and permanent.
 - ▶ Interior - attractive, NSF approved, white aluminum interior liner with 300 series stainless steel floor.
 - ▶ Self closing doors. Positive seal, torsion type closure system.
 - ▶ Triple pane thermal glass door assemblies with extruded aluminum frames.
 - ▶ Patented integrated door light (IDL) system for brighter, shadow free illumination.
 - ▶ Entire cabinet structure is foamed-in-place using high density, CFC free, polyurethane insulation.
- Bottom mounted units feature**
- ▶ "No stoop" lower shelf to maximize product visibility.
 - ▶ Storage on top of cabinet.
 - ▶ Easily accessible condenser coil for cleaning.

ROUGH-IN DATA

Specifications subject to change without notice.

Chart dimensions rounded up to the nearest 1/8" (millimeters rounded up to next whole number).

Model	Doors	Capacity (Cu. Ft.) (liters)	Shelves	Cabinet Dimensions (inches) (mm)			HP	Voltage	Amps	NEMA Config.	Cord Length (total ft.) (total m)	Crated Weight (lbs.) (kg)
				L	D†	H						
GDM-49F	2	49 1388	8	54 ¹ / ₈ 1375	29 ⁷ / ₈ 759	78 ⁵ / ₈ 1998	1 ¹ / ₂ 1 ¹ / ₂	115/208-230/60/1 230-240/50/1	12.3 12.8	14-20P ▲	9 2.74	645 293

† Depth does not include 1 1/8" (29 mm) for door handles.

▲ Plug type varies by country.

Requires 115/208-230/60 Hz, single phase, 3 pole, 4 wire circuit.

	<p>APPROVALS:</p>	<p>AVAILABLE AT:</p>
<p>1/08 Printed in U.S.A.</p>		

Model:
GDM-49F

Glass Door Merchandiser:
Freezer



STANDARD FEATURES

DESIGN

- True's glass door freezers are designed with enduring quality that protects your long term investment.
- True's commitment to using the highest quality materials and oversized refrigeration systems provides the user with colder product temperatures, and lower utility costs in an attractive merchandiser that brilliantly displays frozen food and ice cream.

REFRIGERATION SYSTEM

- Factory engineered, self-contained, capillary tube system using environmentally friendly (CFC free) R404A refrigerant.
- Extra large evaporator coil balanced with higher horsepower compressor and large condenser; maintains -10°F (-23.3°C).
- Sealed, cast iron, self-lubricating evaporator fan motor(s) and larger fan blades give True merchandisers a more efficient low velocity, high volume airflow design. This unique design ensures colder standard temperatures and faster recovery in high use situations.
- Bottom mounted condensing unit positioned for easy maintenance. "No stoop" lower shelf maximizes visibility by raising merchandised product to higher level.
- Automatic defrost system time-initiated, temperature-terminated. Saves energy consumption and provides shortest possible defrost cycle.

CABINET CONSTRUCTION

- Exterior - non-peel or chip white laminated vinyl; durable and permanent.
- Interior - attractive, NSF approved, white aluminum liner with 300 series stainless steel floor.
- Insulation - entire cabinet structure is foamed-in-place using high density, CFC free, polyurethane insulation.

- Welded, heavy duty galvanized frame rail dipped in rust inhibiting enamel paint for corrosion protection inside and out.
- Frame rail fitted with leg levelers.
- Illuminated exterior sign panel. Variety of sign options available.

DOORS

- Triple pane thermal glass door assemblies with extruded aluminum frames.
- Each door fitted with 15" (381 mm) extruded handle.
- Self closing doors. Positive seal, torsion type closure system.
- Magnetic door gaskets of one piece construction, removable without tools for ease of cleaning.

SHELVING

- Eight (8) adjustable, heavy duty PVC coated wire shelves 24⁹/₁₆" L x 20³/₄" D (624 mm x 528 mm). Four (4) chrome plated shelf clips included per shelf.
- Shelf support pilasters made of same material as cabinet interior; shelves are adjustable on 1/2" (13 mm) increments.

LIGHTING

- Safety shielded fluorescent interior lighting. Doors utilize full-length, patented, integrated door light (IDL) system.
- Cabinet lighting utilizes electronic ballast and T-8 bulbs for brighter illumination, longer bulb life and increased energy efficiency.

MODEL FEATURES

- Evaporator is epoxy coated to eliminate the potential of corrosion.
- See our website www.truemfg.com for latest color and sign offerings.
- Backguard and floor rack ensures optimum airflow.

- Listed under NSF-7 for the storage and/or display of packaged or bottled product.

ELECTRICAL

- Unit completely pre-wired at factory and ready for final connection to a 115/208-230/60Hz single phase - 20 amp dedicated outlet. Cord and plug set included.



115/208-230/1
NEMA-14-20R

OPTIONAL FEATURES / ACCESSORIES

Upcharge and lead times may apply.

- 230 - 240V / 50 Hz
- Black exterior.
- Rosewood exterior.
- Stainless exterior.
- Black aluminum interior liner with black shelving.
- 6" (153 mm) standard legs.
- 6" (153 mm) seismic/flanged legs.
- 2 1/2" (64 mm) diameter castors.
- 4" (102 mm) diameter castors.
- Padlock.
- Additional shelves.
- 1 1/4" (32 mm) pricing strips.
- Novelty baskets.
- Remote cabinet and condensing unit, consult factory technical service for BTU information. System comes standard with 404A expansion valve and requires R404A refrigerant.

PLAN VIEW

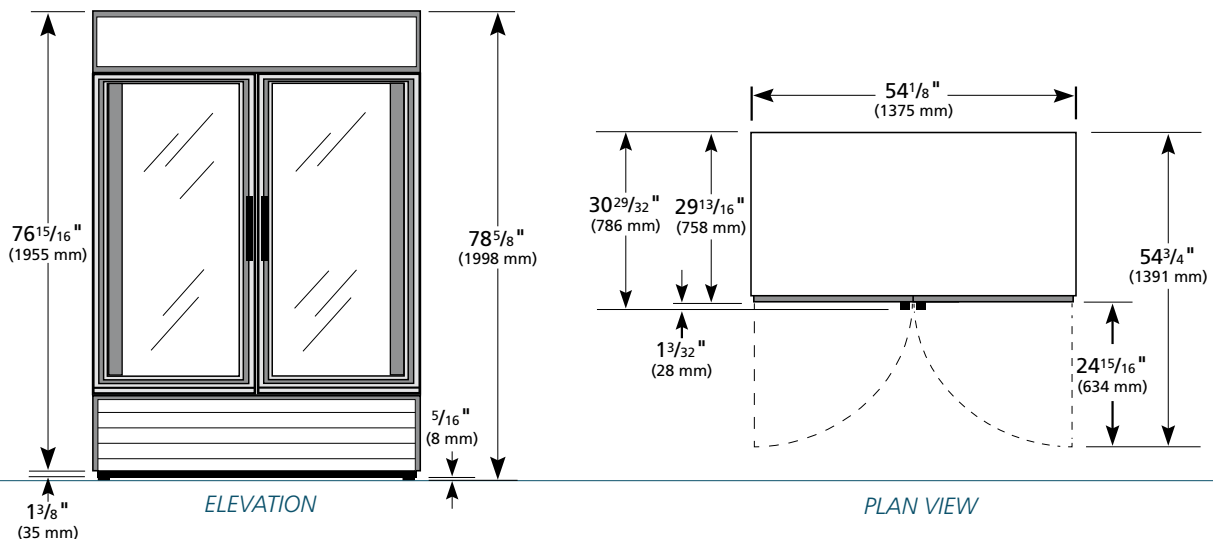

WARRANTY

One year warranty on all parts and labor and an additional 4 year warranty on compressor. (U.S.A. only)

METRIC DIMENSIONS ROUNDED UP TO THE NEAREST WHOLE MILLIMETER
SPECIFICATIONS SUBJECT TO CHANGE WITHOUT NOTICE



Model	Elevation	Right	Plan	3D
GDM-49F	TFAY03E	TFAY03S	TFMY01P	TFAY033

TRUE FOOD SERVICE EQUIPMENT

2001 East Terra Lane • P.O. Box 970 • O'Fallon, Missouri 63366 • (636)240-2400 • Fax (636)272-2408 • (800)325-6152 • Intl. Fax# (001)636-272-7546 • www.truemfg.com