



**TRUE FOOD SERVICE  
EQUIPMENT, INC.**

St. Charles Industrial Center • P.O. Box 970 • O'Fallon, Missouri 63366  
(636)240-2400 • FAX (636)272-2408 • (800)325-6152 • www.truemfg.com  
Parts Dept. (800)424-TRUE • Parts Dept. FAX# (636)272-9471

Project Name: \_\_\_\_\_

A/A #

Location: \_\_\_\_\_

Item #: \_\_\_\_\_ Qty: \_\_\_\_\_

SIS #

Model #: \_\_\_\_\_

Model:  
**T-36-GC**

**Underbar:**  
*Glass & Plate Chiller/Froster*



## T-36-GC

- ▶ True's glass and plate chiller/frosters are designed with enduring quality and value. Our commitment to using the highest quality materials and oversized refrigeration assures colder product temperatures and years of trouble free service.
- ▶ Large storage capacity to meet the supply and demand requirements during peak hours.
- ▶ Oversized, factory balanced, refrigeration system holds 0°F (-17.7°C) and below.
- ▶ Forced-air cooling, positively guided air flow provide efficient balanced temperatures throughout the cabinet. This unique design insures fast frosting of dry glasses and plates.
- ▶ Exterior - heavy duty, wear resistant laminated black vinyl front and sides, matching black aluminum back. All stainless steel countertop and lids.
- ▶ Interior - long lasting, heavy duty galvanized steel.
- ▶ Evaporator - epoxy coated at the time of manufacture to eliminate the potential of corrosion.
- ▶ Entire cabinet structure and lids are foamed-in-place using high density, CFC free, polyurethane insulation.
- ▶ Heavy duty, 10 mil thick pure grade PVC coated adjustable shelves.

## ROUGH-IN DATA

Specifications subject to change without notice.  
Chart dimensions rounded up to the nearest 1/8" (millimeters rounded up to next whole number).

Model	Lids	Capacity		Shelves	Cabinet Dimensions (inches) (mm)			HP	Voltage	Amps	NEMA Config.	Cord Length (total ft.) (total m)	Crated Weight (lbs.) (kg)
		8" (204 mm) Mugs	10 oz. Steins		L	D†	H						
T-36-GC	1	180	172	3	36 <sup>3</sup> / <sub>4</sub> 934	26 <sup>5</sup> / <sub>8</sub> 677	33 <sup>3</sup> / <sub>8</sub> 848	1/3 1/3	115/60/1 230-240/50/1	6.8 2.9	5-15P ▲	9 2.74	225 103

† Depth does not include 1" (26 mm) for rear bumpers.

▲ Plug type varies by country.



APPROVALS:

Model:  
**T-36-GC**

**Underbar:**  
*Glass & Plate Chiller/Froster*



## STANDARD FEATURES

### DESIGN

- True's glass and plate chiller/frosters are designed with enduring quality and value. Our commitment to using the highest quality materials and oversized refrigeration assures colder product temperatures and years of trouble free service.

### REFRIGERATION SYSTEM

- Factory engineered, self-contained, capillary tube system using environmentally friendly (CFC free) 404A refrigerant.
- Extra large evaporator coil balanced with higher horsepower compressor and large condenser; maintains cabinet temperatures of 0°F (-17.7°C) and below.
- Sealed, cast iron, self-lubricating evaporator fan motor and larger fan blades give True chiller/frosters a superior low velocity, high volume airflow design. This unique design insures fast frosting of dry glasses and plates.
- Automatic defrost system time-initiated, time-terminated.
- Condensing unit accessed from behind front grill, slides out for easy maintenance.
- Forced-air cooling, positively guided air flow provide efficient balanced temperatures throughout the cabinet.

### CABINET CONSTRUCTION

- Exterior - heavy duty, wear resistant laminated black vinyl front and sides, matching black aluminum back. All stainless steel countertop and lids.
- Interior - long lasting, heavy duty galvanized steel.
- Insulation - entire cabinet structure is foamed-in-place using high density, CFC free, polyurethane insulation.
- Welded, heavy duty galvanized frame rail dipped in rust inhibiting enamel paint for corrosion protection inside and out.

### SHELVING

- Three (3) adjustable, heavy duty PVC coated wire shelves. One (1) bottom shelf 18<sup>1</sup>/<sub>2</sub>" L x 19<sup>5</sup>/<sub>16</sub>" D (470 mm x 491 mm) and two (2) top shelves 16<sup>1</sup>/<sub>4</sub>" L x 19<sup>3</sup>/<sub>8</sub>" (413 mm x 491 mm). Split shelf design allows for effective rotation of chilled smallware, working with already chilled plates and glasses on one side while chilling dry product on other side.

### MODEL FEATURES

- Evaporator is epoxy coated to eliminate the potential of corrosion.
- Listed under NSF-7 for the storage and/or display of packaged or bottled product.

### ELECTRICAL

- Unit completely pre-wired at factory and ready for final connection to a 115/60/1 phase - 15 amp dedicated outlet. Cord and plug set included.



115/60/1  
NEMA-5-15R

### OPTIONAL FEATURES/ACCESSORIES

Upcharge and lead times may apply.

- 230 - 240V / 50 Hz.
- 6" (153 mm) standard legs.
- 6" (153 mm) seismic/flanged legs.
- 2<sup>1</sup>/<sub>2</sub>" (64 mm) diameter castors.
- 3" (77 mm) diameter castors.
- Ratchet lock.
- Floor racks.
- Remote cabinets (condensing unit supplied by others), consult factory technical service department for BTU information.

## PLAN VIEW

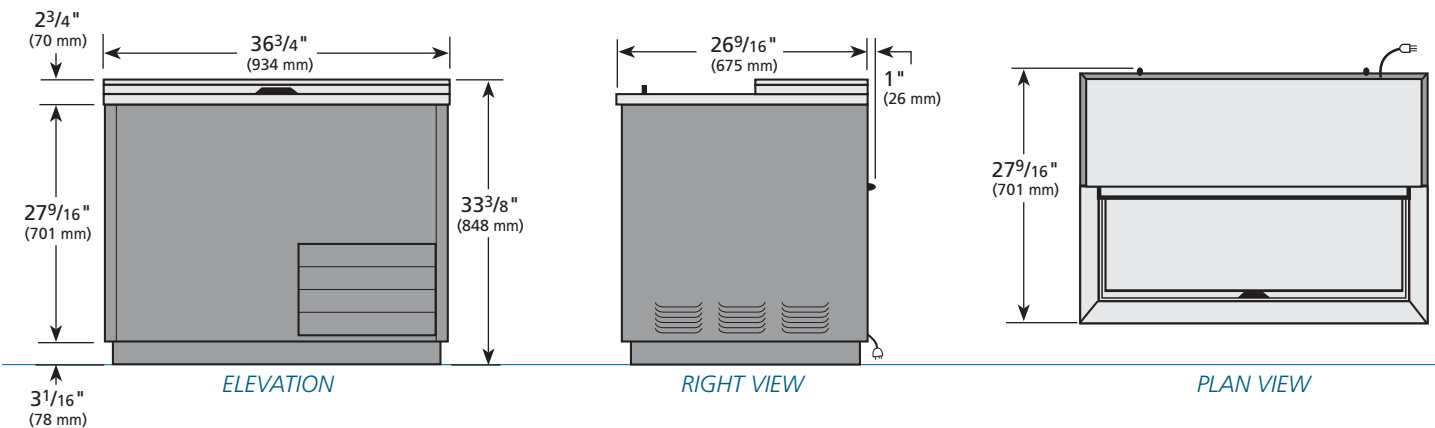

### WARRANTY

One year warranty on all parts & labor and an additional 4 year warranty on compressor. (U.S.A. only)

METRIC DIMENSIONS ROUNDED UP TO THE NEAREST WHOLE MILLIMETER

SPECIFICATIONS SUBJECT TO CHANGE WITHOUT NOTICE



Model	Elevation	Right	Plan	3D
T-36-GC	TFLY02E	TFLY01S	TFLY02P	TFLY023

## TRUE FOOD SERVICE EQUIPMENT

St. Charles Industrial Center • P.O. Box 970 • O'Fallon, Missouri 63366 • (636)240-2400 • FAX (636)272-2408 • (800)325-6152 • www.truemfg.com