



TRUE FOOD SERVICE EQUIPMENT, INC.

St. Charles Industrial Center • P.O. Box 970 • O'Fallon, Missouri 63366
 (636)240-2400 • FAX (636)272-2408 • (800)325-6152 • www.truemfg.com
 Parts Dept. (800)424-TRUE • Parts Dept. FAX# (636)272-9471

Project Name: _____

A/A #

Location: _____

Item #: _____ Qty: _____

SIS #

Model #: _____

Model:
GDM-26

Glass Door Merchandiser:
Swing Door Refrigerator



GDM-26

- ▶ The world's #1 manufacturer of glass door merchandisers.
 - ▶ Oversized, factory balanced, refrigeration system holds 33°F to 38°F (.5°C to 3.3°C).
 - ▶ Exterior - non-peel or chip white laminated vinyl; durable and permanent.
 - ▶ Interior - attractive, NSF approved, white aluminum interior liner with 300 series stainless steel floor.
 - ▶ Self closing doors. Positive seal, torsion type closure system.
 - ▶ "Low-E", double pane thermal glass door assembly with extruded aluminum frame. The latest in energy efficient technology.
 - ▶ Patented integrated door light (IDL) system for brighter, shadow free illumination.
 - ▶ Entire cabinet structure are foamed-in-place using high density, CFC free, polyurethane insulation.
- Bottom mounted units feature**
- ▶ "No stoop" lower shelf to maximize product visibility.
 - ▶ Storage on top of cabinet.
 - ▶ Easily accessible condenser coil for cleaning.

Shown with optional True Trac4 gravity feed organizer.

ROUGH-IN DATA

Specifications subject to change without notice.

Chart dimensions rounded up to the nearest 1/8" (millimeters rounded up to next whole number).

Model	Glass Doors	Capacity (Cu. Ft.) (liters)	# of Shelves	Cabinet Dimensions (inches) (mm)			HP	Voltage	Amps	NEMA Config.	Cord Length (total ft.) (total m)	Crated Weight (lbs.) (kg)
				L	D†	H						
GDM-26	1	26 737	4	30	29 ⁷ / ₈	78 ⁵ / ₈	1/3	115/60/1	7.2	5-15P	9	325
				762	759	1998	1/3	230-240/50/1	4.0	▲	2.74	148

† Depth does not include 1/8" (29 mm) for door handle.

▲ Plug type varies by country.



APPROVALS:

Model:
GDM-26

Glass Door Merchandiser:
Swing Door Refrigerator



STANDARD FEATURES

DESIGN

- True's commitment to using the highest quality materials and oversized refrigeration systems provides the user with colder product temperatures, and lower utility costs in an attractive merchandiser that brilliantly displays packaged food and beverages.

REFRIGERATION SYSTEM

- Factory engineered self-contained, capillary tube system using environmentally friendly (CFC free) 134A refrigerant.
- Extra large evaporator coil balanced with higher horsepower compressor and large condenser; maintains 33°F to 38°F (5°C to 3.3°C).
- Sealed, cast iron, self-lubricating evaporator fan motors and larger fan blades give True merchandisers a superior low velocity, high volume airflow design. This unique design insures faster temperature pull down of warm product, colder holding temperatures and faster recovery in high use situations.
- Bottom mounted condensing unit positioned for easy maintenance. "No stoop" lower shelf maximizes visibility by raising merchandised product to higher level.

CABINET CONSTRUCTION

- Exterior - non-peel or chip white laminated vinyl; durable and permanent.
- Interior - attractive, NSF approved, white aluminum liner with 300 series stainless steel floor.

- Insulation - entire cabinet structure is foamed-in-place using high density, CFC free, polyurethane insulation.
- Welded, heavy duty galvanized frame rail dipped in rust inhibiting enamel paint for corrosion protection inside and out.
- Frame rail fitted with leg levelers.
- Illuminated exterior sign panel. Variety of sign options available.

DOORS

- "Low-E", double pane thermal glass door assembly with extruded aluminum frame. The latest in energy efficient technology.
- Self closing door. Positive seal, torsion type closure system.
- Door fitted with 12" (305 mm) extruded aluminum handles.
- Magnetic door gaskets of one piece construction, removable without tools for ease of cleaning.

SHELVING

- Four (4) adjustable, heavy duty PVC coated wire shelves 25^{11/16}"L x 23^{1/4}"D (653 mm x 591 mm). Four (4) chrome plated shelf clips included per shelf.
- Shelf support pilasters made of same material as cabinet interior; shelves are adjustable on 1/2" (13 mm) increments.

LIGHTING

- Safety shielded fluorescent interior lighting. Door utilizes full-length, patented, integrated doors light (IDL) system.
- Cabinet lighting utilizes electronic ballast and T-8 bulbs for brighter illumination, longer bulb life and increased energy efficiency.

MODEL FEATURES

- Evaporator is epoxy coated to eliminate the potential of corrosion.
- See our website www.truemfg.com for latest color and sign offerings.
- Convenient clean-out drain built in cabinet floor.

ELECTRICAL

- Unit completely pre-wired at factory and ready for final connection to a 115/60/1 phase - 15 amp dedicated outlet. Cord and plug set included.



115/60/1
NEMA-5-15R

OPTIONAL FEATURES/ACCESSORIES

Upcharge and lead times may apply.

- 230 - 240V/50 Hz.
- Black exterior.
- Rosewood exterior.
- Stainless steel exterior.
- Black aluminum interior with black shelving.
- Stainless interior liner.
- 6" (153 mm) standard legs.
- 6" (153 mm) seismic/flanged legs.
- 2 1/2" (64 mm) diameter castors.
- 4" (102 mm) diameter castors.
- Red wine thermostat.
- White wine thermostat.
- Chocolate thermostat.
- Barrel locks.
- TrueTrac4 gravity feed organizers.
- 1 1/4" (32 mm) pricing strips.
- Remote cabinets (condensing unit supplied by others), consult factory technical service department for BTU information.

PLAN VIEW

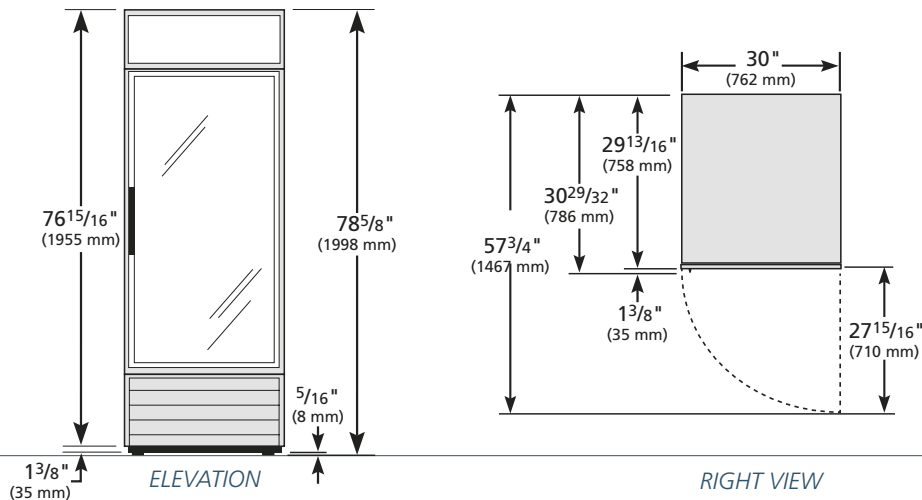

WARRANTY
One year warranty on all parts & labor and an additional 4 year warranty on compressor. (U.S.A. only)

METRIC DIMENSIONS ROUNDED UP TO THE NEAREST WHOLE MILLIMETER
SPECIFICATIONS SUBJECT TO CHANGE WITHOUT NOTICE



Model	Elevation	Right	Plan	3D
GDM-26	TFAY09E	TFAY09S	TFAY09P	TFAY093

TRUE FOOD SERVICE EQUIPMENT