

Project	Quantity	Item #
Model Specified:		CSI Section 11400

Compact Prep Table Refrigerators/ Self-Contained

48" Wide Models



Stainless Exterior,
Anodized
Aluminum Interior

48" Wide Eight Pan Capacity Model UPT488
48" Wide Twelve Pan Capacity Model UPT4812
48" Wide Eighteen Pan Capacity Model UPT4818



Model UPT4812
(shown with optional casters)

Finally there is a compact prep table product worthy of the Traulsen name. Their rugged construction and high quality components make these units capable of standing up to the demanding environment of any foodservice kitchen. Each unit is built with a high quality stainless steel exterior and durable anodized aluminum interior.

They are also designed for high performance, providing accurate temperature maintenance within NSF Standard 7 guidelines. Fresh, safe food is assured, even under the most demanding conditions.

Their front breathing design allows for "zero-clearance" installation. As a result they can be placed right up against the backwall and alongside other kitchen equipment, saving valuable floor space. Additionally, they are supplied with top cut-outs in order to accommodate sixth size food pans. A full compliment of 4" deep sixth size plastic pans is provided.

Standard Product Features

- Stainless Steel Exterior Top, Sides & Doors
- Anodized Aluminum Interior
- Front Breathing Self-Contained Refrigeration System
- Environmentally Friendly R-134a Refrigerant
- Top Cut-Outs To Accommodate Sixth Size Pans
- Full Compliment Of Plastic Sixth Size Pans Provided
- Removable Stainless Steel Pan Cover With Pivoting Front Lid
- Reversible Full Length Nylon Cutting Board
- Self-Closing Stainless Steel Doors With Stay Open Feature At 105 Degrees
- Horizontal Work Flow Door Handles
- Anodized Aluminum Interior Door Liners
- Standard Door Hinging, All Models: Left/Right (other hingsings also available)
- Interior Mounted Thermometer
- Two (2) Powder Coated Shelves Per Door, Mounted On Pilasters
- Automatic Non-Electric Condensate Evaporator
- Magnetic Snap-In Door Gaskets
- 8' Cord & Plug Attached
- Set of Four (4) 6" High Adjustable Legs
- One Year Parts And Labor Warranty
- Five Year Compressor Warranty

Options & Accessories

- Stainless Steel Finished Back
- Additional Powder Coated Shelves
- 6" Overall Height Casters (for use in lieu of legs)
- 4" Overall Height Casters (for use in lieu of legs)
- 3-1/2" Overall Height Casters (for use in lieu of legs)
- 4" High Stainless Steel Utility Base (for use in lieu of legs)
- Two Year Service/Labor Warranty Available



Listed by Underwriters Laboratories Inc., to U.S. and Canadian safety standards and Listed by NSF International in accordance with ANSI/NSF7.

Approval: _____



TRAULSEN
4401 BLUE MOUND RD.
PHONE 1 (800) 825-8220
Website: www.traulsen.com

FT. WORTH, TX 76106
FAX-MKTG. 1 (817) 624-4302

SECTION
9-4

Project	Quantity	Item #
Model Specified:		CSI Section 11400

Model UPT488

Eight (8) Sixth Size Pan Capacity
Compact Undercounter
Refrigerator Model
(eight 4" deep sixth size plastic pans provided)

Elevation - UPT488

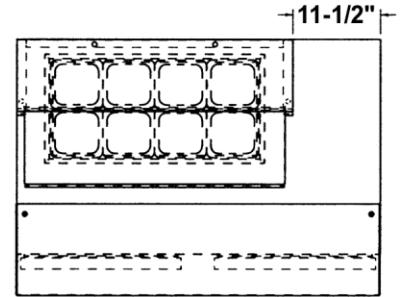
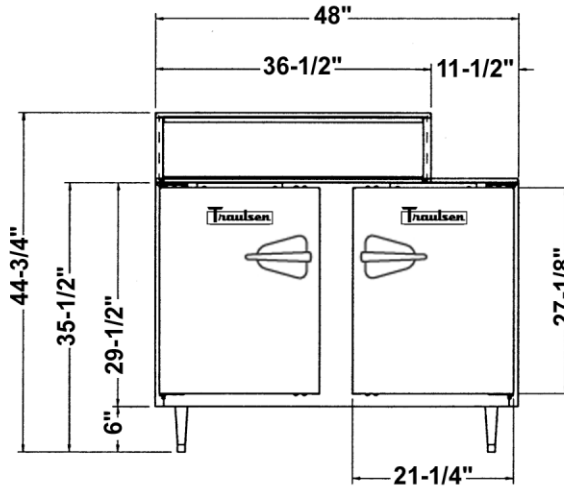

Plan - UPT488

Model UPT4812

Twelve (12) Sixth Size Pan Capacity
Compact Undercounter
Refrigerator Model
(twelve 4" deep sixth size plastic pans provided)

Elevation - UPT4812

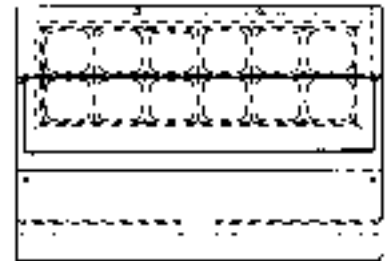
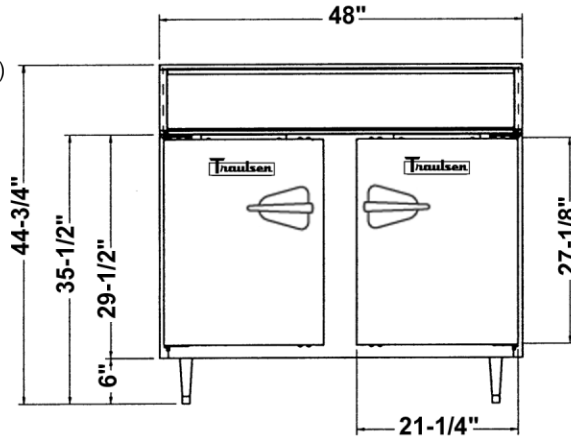

Plan - UPT4812

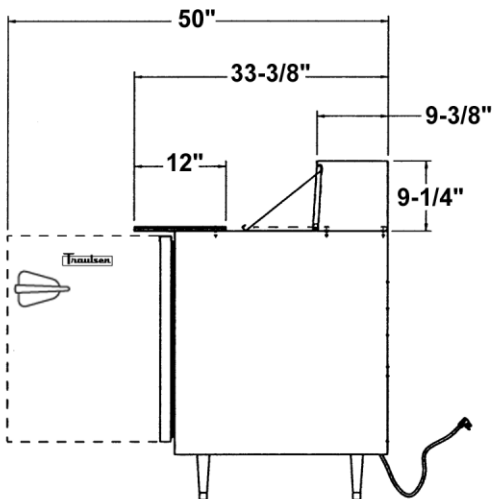

Section - UPT488

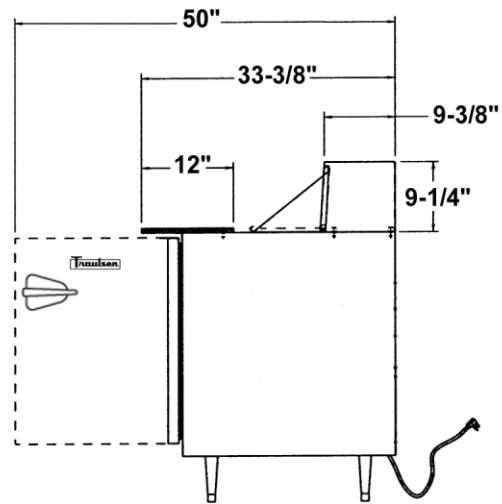

Section - UPT4812

Project	Quantity	Item #
Model Specified:		CSI Section 11400

Model UPT4818

Eighteen (18) Sixth Size Pan Capacity
 Compact Undercounter
 Refrigerator Model
 (eighteen 4" deep sixth size plastic pans provided)

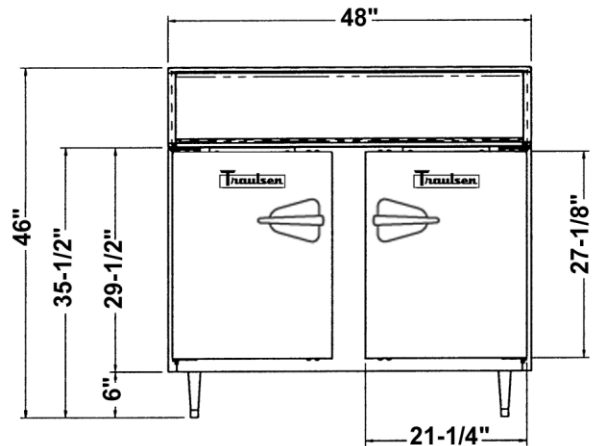

Elevation - UPT4818

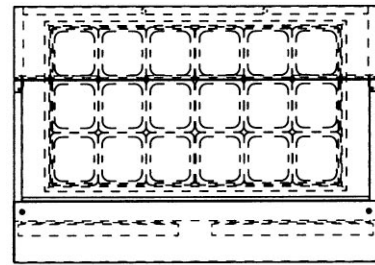

Plan - UPT4818

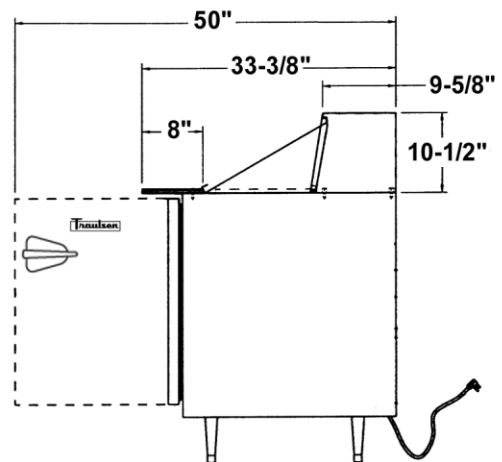

Section - UPT4818



TRAULSEN
 4401 BLUE MOUND RD.
 PHONE 1 (800) 825-8220
 Website: www.traulsen.com

FT. WORTH, TX 76106
 FAX-MKTG. 1 (817) 624-4302

SECTION
 9-4

Project	Quantity	Item #
Model Specified:		CSI Section 11400

Specifications

Construction, Hardware and Insulation

Cabinet exterior front, one piece sides, louver assembly and doors are constructed of 22 gauge stainless steel. Cabinet interior and door liners are constructed of anodized aluminum. The exterior cabinet back and bottom are constructed of galvanized steel.

A stainless steel door with a recessed work-flow handle and anodized aluminum liner is provided. The door self closes at less than 90 degrees and also includes a stay open feature at 105 degrees. Easily removable for cleaning, vinyl magnetic door gasket assures tight door seal.

Both the cabinet and door(s) are insulated with an average of 2" thick high density, non-CFC, foamed in place polyurethane.

A full length reversible nylon cutting board, 12" wide (for models UPT488 and UPT4812) or 8" wide (for model UPT4818) is supplied standard.

Pans & Cover

Each model is supplied standard with its full compliment of 4" deep plastic sixth size pans and stainless steel pan dividers. The pivoting pan cover is constructed of stainless steel, and is removable for cleaning.

Refrigeration System

A balanced, rear mounted, front breathing, self-contained refrigeration system using R-134a refrigerant is provided. It features a capillary tube metering device, air-cooled hermetic compressor, a forced air evaporator coil and a non-electric condensate evaporator. An 8' cord and plug is provided. Standard operating temperature is 34 to 38°F.

Interior

Standard interior arrangements include two (2) powder coated wire shelves per door, mounted on pilasters. These are adjustable in 1/2" increments, allowing for a minimum of 1-1/2" spacing between shelves.

Warranties

Both a one year parts and labor warranty and a five year compressor warranty (self-contained models only) are provided standard. An optional 2nd year extended parts and labor warranty is also available.

DIMENSIONAL DATA	UPT488	UPT4812	UPT4818
Net capacity cu. ft.	13.1	13.1	13.1
Length - overall in.	48	48	48
Depth - overall in. ¹	33 $\frac{3}{8}$	33 $\frac{3}{8}$	33 $\frac{3}{8}$
Depth - with door open 90°	50	50	50
Clear door height in.	24 $\frac{1}{8}$	24 $\frac{1}{8}$	24 $\frac{1}{8}$
Clear door width in.	18 $\frac{1}{4}$	18 $\frac{1}{4}$	18 $\frac{1}{4}$
Height - overall on 6" legs in.	44 $\frac{3}{4}$	44 $\frac{3}{4}$	46
Number of shelves - total	4	4	4
Shelf area sq. ft.	10.3	10.3	10.3
Pan Capacity - Sixth Size	8	12	18
ELECTRICAL DATA			
Voltage	115/60/1	115/60/1	115/60/1
Full Load Amperes	6.3	6.3	6.3
Wattage	520	520	520
REFRIGERATION DATA			
Refrigerant	R-134a	R-134a	R-134a
BTU/HR - H.P. ²	1600 (1/4 HP)	1600 (1/4 HP)	1600 (1/4 HP)
SHIPPING DATA			
Net Wt. lbs.	285	285	285
Gross Wt. lbs.	300	300	300

NOTES

- 1= Overall depth figure includes standard cutting board.
 2= Based on a 90 degree F ambient and 20 degree F evaporator.



Equipped With One NEMA 5-15 P Plug

NOTE: When ordering please specify: Voltage, Hinging, Optional Accessories and any additional warranties.

Continued product development may necessitate specification changes without notice.
 Part No. TR35822 (revised 9/03)

NOTE: Freight charges are FOB destination for dock to dock delivery within the continental USA. Liftgate delivery charges are additional. For inside delivery charges, please consult factory.

**SECTION
9-4**

TRAULSEN
 4401 BLUE MOUND RD.
 PHONE 1 (800) 825-8220
 Website: www.traulsen.com

FT. WORTH, TX 76106
 FAX-MKTG. 1 (817) 624-4302

