

Project	Quantity	Item #
Model Specified:		CSI Section 11400

200 lb. Capacity Roll-In & Roll-Thru Blast Chiller Models



Roll-In Model **RBC200**
Roll-Thru Model **RBC200RT**



Model RBC200
(shown with optional roll-in rack)

Model RBC200RT



Like all blast chillers, Traulsen's model RBC200 and RBC200RT are designed to quickly cool their respective capacity of hot product through the HACCP danger zone as fast, or faster, than any other equivalent brand on the market (approximately 90-minutes). However, in addition to the outstanding cabinet construction synonymous with Traulsen, what differentiates these models from competition is the operational flexibility and labor savings inherent in their easy-to-use controls, automatic HACCP documentation, and a variety of operator friendly features, such as our exclusive "By-Product" chill mode.

Both models require provision of one (1) 4 HP remote condensing unit for blast chill operation (installation by others). If purchased from Traulsen, this includes a five year warranty.

High Quality Standard Features

- Stainless Steel Exterior & Interior Construction
- Communications Capable & NAFEM Data Protocol Compliant
- On-Board Batch Data Printer
- Three (3) Chilling Functions
 - 1) Blast Chill (135° to below 41°F in approx. 90-minutes)
 - 2) Soft Chill (for use with delicate products such as fresh seafood and produce)
 - 3) Freeze temp can be set for as low as -22°F)
- Three (3) Chilling Modes For Each Chilling Functions
 - 1) By Temperature
 - 2) By Product
 - 3) By Time
- Automatic Refrigerated Hold Mode After Each Cycle
- Dual Self-Contained Refrigeration Systems (promotes energy efficient operation and maximizes compressor life)
- Accommodates One (1) Roll-In Rack With Maximum Dimensions Of: H=72" x W=27" x D=29" (not supplied standard, see "Options & Accessories")
- Magnetic Door Gasket(s)
- Stainless Steel Breaker Caps
- Stainless Steel Roll-In Ramp(s) & Rack Guides
- Self-Closing and Stay Open Door Features
- Rehingable Door with Lock (Standard Left Hinging)
- Horizontal Work Flow Door Handle(s) Guaranteed for Life
- Automatic Defrost With On-Demand Feature
- Adjustable Product Chill Target Temperatures
- Adjustable Product Holding Temperature
- One Year Parts/Labor Warranty
- Five Year Compressor Warranty on 3/4 HP Holding Compressor

Exclusive Standard Features

- Easy-to-Use SmartChill® Control System
- One Button EZ-START™ Feature
- Three (3) SmartProbes™ Automatically Register Product Temperatures
- On-Board Label Printer (prints adhesive labels which can be placed right directly on to product containers)
- By Product Chill Mode (allows the operator to pre-program into memory the individual chilling requirements of a variety of different food products)

Options & Accessories

- Correctional Facility Package for Blast Chill
- For Other Voltage Options Consult Factory
- One or Two Day On-Site Blast Chill Training
- Two Year Service Labor Warranty Available
- BCACC-60111: 208-230/60/1 4HP Air-Cooled Remote Condensing Unit - Includes 5 Year Warranty
- BCACC-60123: 208-230/60/3 4HP Air-Cooled Remote Condensing Unit - Includes 5 Year Warranty
- BCACC-60121: 208-230/60/1 3HP Water-Cooled Remote Condensing Unit - Includes 5 Year Warranty
- BCACC-OTRTR: Special Blast Chiller Roll-In Rack (accommodates up to 26-12" x 20" pans)
- BCACC-60387: SmartChill® Communications Software Pkg.
- BCACC-NDPG1: Communications Gateway (required for use within a NAFEM Data Protocol compliant network)
- BCACC-60122: Remote Condensing Unit Weather Housing
- BCACC-60073: Leg Kit For Remote Condensing Unit
- BCACC-FMCE: 115V Floor-Mounted Condensate Evaporator
- Modification For Use With Hobart CE20 Combi Oven Racks - See Page 4 For Details (for use with other brands please contact factory)



Listed by Underwriters Laboratories Inc. and CSA certified by Underwriters Laboratories Inc. and classified by Underwriters Laboratories in accordance with ANSI/NSF7.

Approval: _____



TRAULSEN
4401 BLUE MOUND RD.
PHONE 1 (800) 825-8220
Website: www.traulsen.com

FT. WORTH, TX 76106
FAX-MKTG. 1 (817) 624-4302

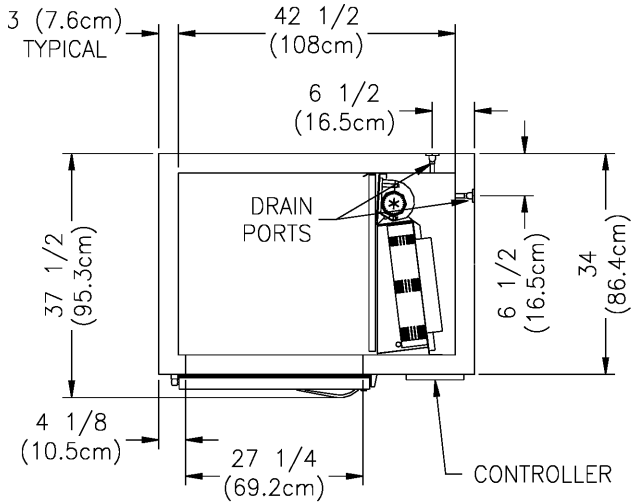

MODEL DESCRIPTION
RBC200

NOTE: UNIT REQUIRES CONDENSATE REMOVAL VIA FLOOR SINK OR OPTIONAL CONDENSATE EVAPORITIVE PAN KIT.

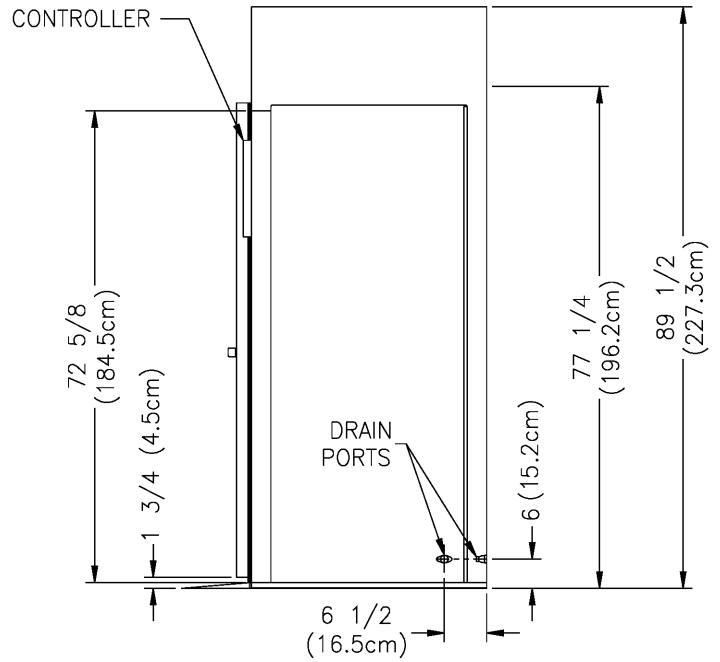
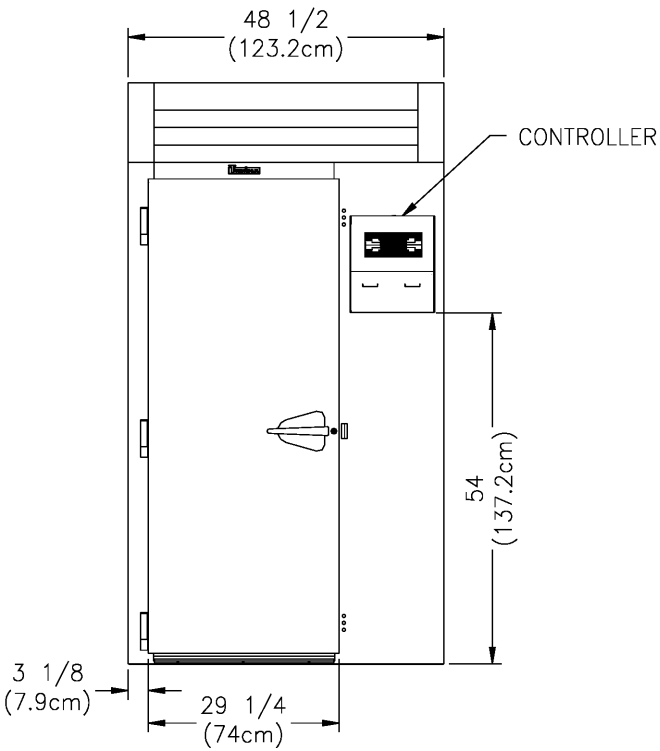

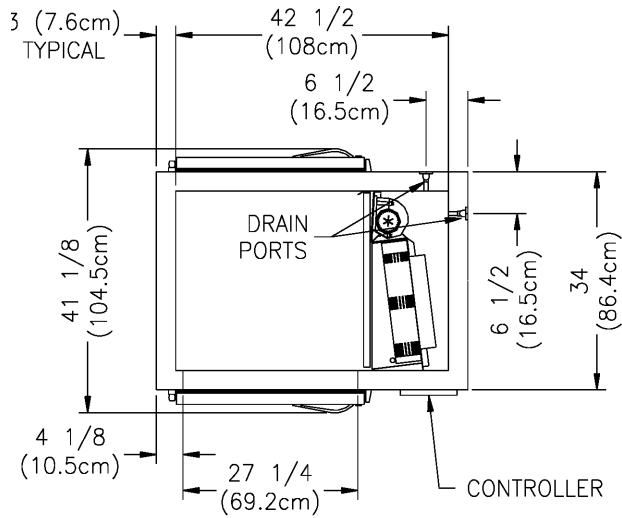

MODEL DESCRIPTION
RBC200RT

NOTE: UNIT REQUIRES CONDENSATE REMOVAL VIA FLOOR SINK OR OPTIONAL CONDENSATE EVAPORITIVE PAN KIT.

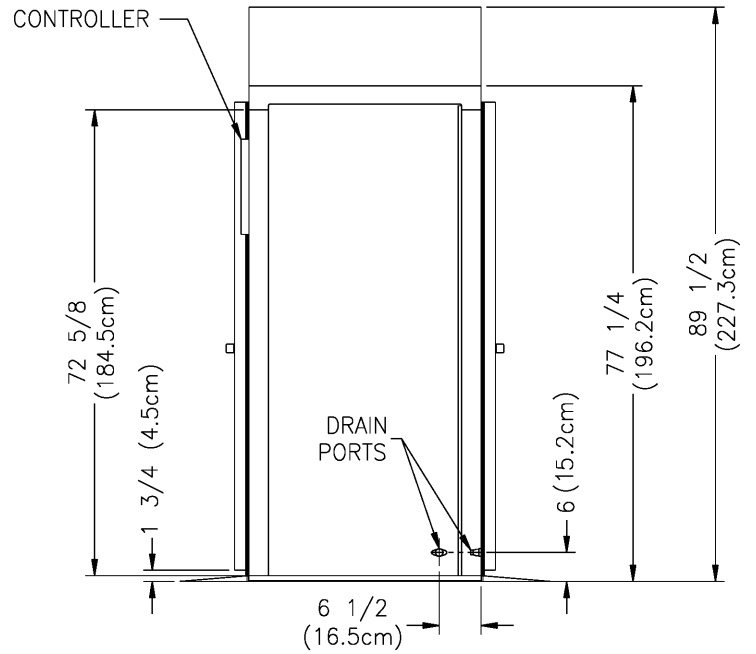
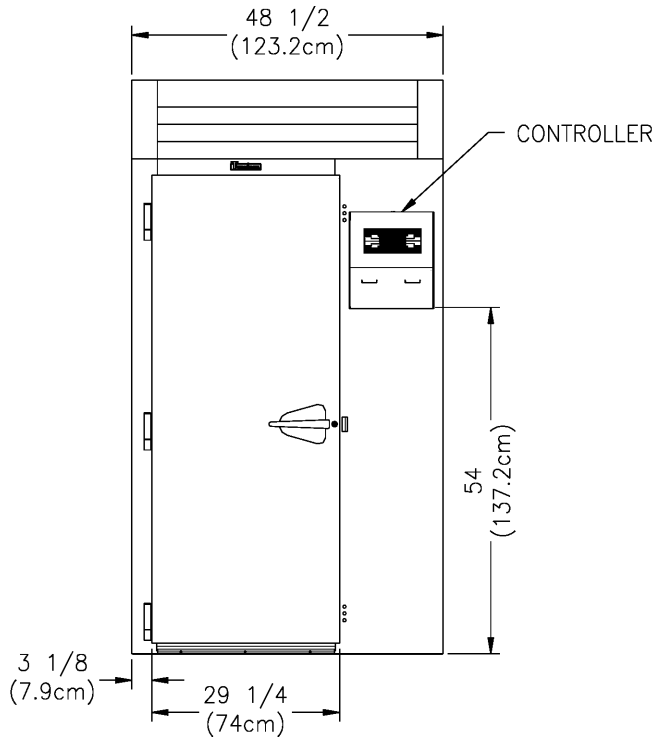

TRAUlsen
4401 BLUE MOUND RD.
PHONE 1 (800) 825-8220
Website: www.traulsen.com

FT. WORTH, TX 76106
FAX-MKTG. 1 (817) 624-4302

Project	Quantity	Item #
Model Specified:		CSI Section 11400

Specifications

Construction, Hardware and Insulation

Exterior sides, front, rear, door and interior are constructed of heavy gauge stainless steel. The exterior top and bottom are constructed of heavy gauge galvanized steel. The interior floor is constructed of stainless steel and insulated with 3/4" of resilient cork. Door(s) are equipped with guaranteed for life cam lift hinges with stay open feature at 120°. Guaranteed for life, work flow handle is mounted horizontally over recess in door which limits protrusion from door face into aisle ways. Door is standard with cylinder lock. Easily removable for cleaning, vinyl magnetic gasket assures tight door seal. Anti-condensate heater is located behind door opening. Door is hinged left as supplied standard. Both cabinet and door are insulated with high density, non-CFC foamed in place polyurethane.

Refrigeration System

Dual refrigeration systems are utilized in order to prevent short cycling, providing for energy efficient operation and maximizing compressor life. These combine their efforts through a unique air circulation system within the food zone. During Blast Chill cycles both systems are in full operation. At the completion of any chill or freeze cycle, one refrigeration system remains in use to maintain proper refrigerated storage temperatures. Each unit requires a separate 4 HP remote condensing unit for blast chill operation, and a floor drain or optional condensate evaporator for condensate removal.

Blast Chill Operation

In Blast Chill mode both refrigeration systems, as well as four blowers are in operation. Cabinet air temperature can be as low as 0°F. The control closely monitors both the air and product temperatures to assure rapid chilling without freezing. The operator is notified upon completion of each chill cycle, and the unit automatically begins to maintain proper refrigerated storage temperatures. All chill cycle data is then stored in memory and can either be printed or downloaded to a PC on demand.

Controller

The SmartChill® microprocessor system operates using a familiar "ATM" type interface, providing for ease of training and use. The control allows the chiller to be operated in any one of three different chilling functions, and in any one of three modes. HACCP documentation is facilitated by two on-board printers which record all required product chill cycle information. This same data can also be downloaded to a PC using optional SmartChill® communications software (available from Traulsen) or via optional NAFEM Data Protocol Compliant hardware and software (by others). An instructional DVD is included.

Roll-In Racks

Readily removable, interior mounted stainless steel guides for rack are provided. Maximum rack size with wheels inboard of frame is 27" wide by 29" deep by 72" high. Racks are typically supplied by others, however these may be purchased directly from Traulsen as an option.

Warranties

The standard warranty is a one year parts and labor warranty on all components and the cabinet, and an additional four year parts only warranty on the 3/4 HP maintenance compressor. Additional warranties are available at extra cost.

An on-site service validation is provided by an authorized agent at no-charge upon installation in order to insure proper operation.

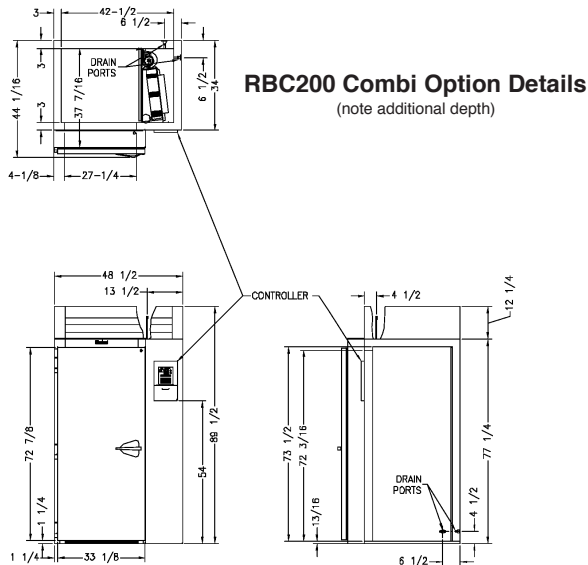

DIMENSIONAL DATA	RBC200 Roll-In	RBC200RT Roll-Thru
Net Capacity cu. ft.	35 (990.5 l)	35 (990.5 l)
Number of Pans 12" x 20" x 2 1/2" # of Pans Depends Upon Rack Purchased	26	26
Rack Capacity (see "Roll-In Racks")	1	1
Length Overall in.	48 1/2 (123.2 cm)	48 1/2 (123.2 cm)
Depth - Cabinet Only in. / Over Body in.	34 (86.4 cm)	34 (86.4 cm)
Depth - with Door Open 90° in.	65 1/8 (165.4 cm)	96 1/4 (244.5 cm)
Depth - Overall in.	37 1/2 (95.3 cm)	41 1/8 (104.5 cm)
Clear Door Width in.	27 1/4 (69.2 cm)	27 1/4 (69.2 cm)
Clear Door Height in.	72 5/8 (184.5 cm)	72 5/8 (184.5 cm)
Height - Overall in.	89 1/2 (227.3 cm)	89 1/2 (227.3 cm)
ELECTRICAL DATA		
Voltage	115/60/1	115/60/1
Feed Wires with Ground	3	3
Full Load Amperes	15.2	15.2
Minimum Circuit Ampacity	20	20
Wattage	1725	1725
REFRIGERATION DATA Holding System Only		
Refrigerant	R404a	R404a
BTU/HR - HP - 3/4 HP Holding Compressor	3880	3880
Heat Load - BTU/HR	7000	7000
Suction Line in.	3/8 (.95 cm)	3/8 (.95 cm)
Liquid Line in.	1/4 (.63 cm)	1/4 (.63 cm)
REMOTE CONDENSER (Note: all models require a remote condenser unit. For additional technical support on optional remote condenser units consult factory.)		
REFRIGERATION DATA		
Refrigerant	R404a	R404a
Voltage	208-230/60/1	208-230/60/1
Recommended BTU/HR - HP	18,700 - 4 HP	18,700 - 4 HP
BTU's are rated at 90° F ambient and a -10° F evaporator temp.		
Suction Line in. Ref. Lines at Blast Chill Unit	7/8 (2.2 cm)	7/8 (2.2 cm)
Liquid Line in. Ref. Lines at Blast Chill Unit	1/2 (1.3 cm)	1/2 (1.3 cm)
Suction Line in. Ref. Line on Remote Condenser	1 1/8 (2.9 cm)	1 1/8 (2.9 cm)
Liquid Line in. Ref. Line on Remote Condenser	1/2 (1.3 cm)	1/2 (1.3 cm)

NOTE

Figures in parentheses reflect metric equivalents

*REMOTE COMPRESSOR NOTES:

- 1 - See form TR35802 for remote compressor specifications.
- 2 - Remote compressor installation required by others. Traulsen provides an service agent validation upon completion of remote system installation at no-charge (call 800-825-8220 in order to arrange this).
- 3 - Remote compressor includes a five year warranty if purchased from Traulsen.



Equipped With One NEMA 5-20 P Plug

NOTE: Full load amps and plug style may vary depending on electrical options chosen and condensing unit employed.

Continued product development may necessitate specification changes without notice.
Part No. TR35799 (revised 1/10)

TRAULSEN
4401 BLUE MOUND RD.
PHONE 1 (800) 825-8220
Website: www.traulsen.com

FT. WORTH, TX 76106
FAX-MKTG. 1 (817) 624-4302

Traulsen