

THERMA-TEK

R A N G E C O R P .

Therma-Tek Range Corp.
115 Rotary Drive, Valmont Industrial Park
West Hazleton, PA 18202



TMDS36-6-1
(Optional casters shown)

NOTE: Ranges supplied with casters must be installed with an approved restraining device.

OPTIONAL FEATURES

- * 6" (152.5 mm) swivel casters.
- * Gas flex hose w/ quick disconnect and restraining device.
- * Extra oven rack.
- * Range based convection oven.
- * 17" (432 mm) High Backguard.
No charge in lieu of high shelf.
- * 10" (254 mm) Low Profile Backguard.
No charge in lieu of high shelf.
- * Thicker griddle plates are optional.
- * Thermostat controlled griddles.
- * Hot tops 12" sections (305 mm).
- * Galvanized exterior sides, aluminized oven interior with porcelain oven bottom and door panel (TMDE model).
- * Stainless steel exterior with fully porcelainized oven interior (TMDU model).
- * CE-approved flame failure device available on most models.

GAS RESTAURANT RANGE 36"

GENERAL SPECIFICATIONS

Gas medium duty range 36" (914.5 mm) wide with full size oven accepting 18" x 26" (457 mm x 660 mm) sheet pans in either direction. Oven is heated by a heavy duty straight tube burner. Lift off cast iron open top burners. Individual top grates for each burner. Available ¾ inch (19mm) thick griddle plate. Valve controlled or thermostatically controlled. Griddles are heated by a heavy duty "H" burner. Available with hot tops in 12" (305 mm) sections. Hot tops are heated by heavy duty "H" burners. Aluminized oven interior. Porcelain inner door panel and removable oven bottom. Fully stainless steel exterior. Single deck high shelf is standard.

STANDARD FEATURES

- * Fully stainless steel exterior including single deck high shelf.
- * 6" (152.5 mm) adjustable legs.
- * 5" (127 mm) stainless steel front rail.
- * Gas pressure regulator.
- * One year limited parts and labor warranty.

OVEN

- * Heavy gauge welded frame construction.
- * Aluminized oven interior. Porcelain inner door panel and removable oven bottom.
- * Oven dimensions 26¼" wide, 27" deep, 14 9/16" high (667 mm x 686 mm x 363.5 mm).
- * Removable chrome plated oven side racks.
- * One chrome plated oven rack.
- * Ribbed oven door for added strength.
- * Thermostat is adjustable from 150° F to 500° F (66° C to 260° C).
- * Heavy duty straight tube burner @ 35,000 BTU's (10.25 kW).
- * Push button spark igniter for pilot.

OPEN TOP BURNERS

- * Cast iron lift off burners rated at 30,000 BTU's (8.79 kW).
- * Spill-proof pilot ignition system.
- * Individual cast iron top grates.
- * Controlled by a brass valve with infinite adjustment.

GRIDDLES

- * ¾" (19 mm) thick polished steel plate.
- * 21½" (546 mm) working depth.
- * Spatula width grease trough.
- * One heavy duty "H" burner per 12" (305 mm) section @ 20,000 BTU's (5.86 kW).
- * Each 12" (305 mm) section is controlled by a valve or a thermostat.
- * Manual control is standard.
- * Thermostat control is optional.
- * Large capacity grease container with integral lid.

HOT TOP

- * Heavy cast hot top available in 12" (305 mm) sections.
- * Heavy duty "H" burner per 12" (305 mm) section @ 20,000 BTU's (5.86 kW).
- * Hot top surface is level with open top burners for easy movement of pots.

RADIANT CHAR BROILER

- * Cast iron H-type burner per 12" section; at 30,000 BTU/hr (8.79kW).
- * Heavy cast-iron radiants with multiple heat sinks.
- * Heavy-duty cast-iron grates for maximum heat retention.
- * Single piece precision brass valves with infinite heat control.

CHAR-ROCK BROILERS

- * Cast iron H-type burner per 12" section; at 30,000 BTU/hr (8.79kW).
- * High quality lava rocks on cast iron supports provide maximum heat.
- * Burners protected by heat shield to prevent blockage of ports and pilots.
- * Heavy-duty cast-iron grates for maximum heat retention.
- * Single piece precision brass valves with infinite heat control.

THERMA-TEK

RANGE CORP.

Therma-Tek Range Corp.
115 Rotary Drive, Valmont Industrial Park
West Hazleton, PA 18202

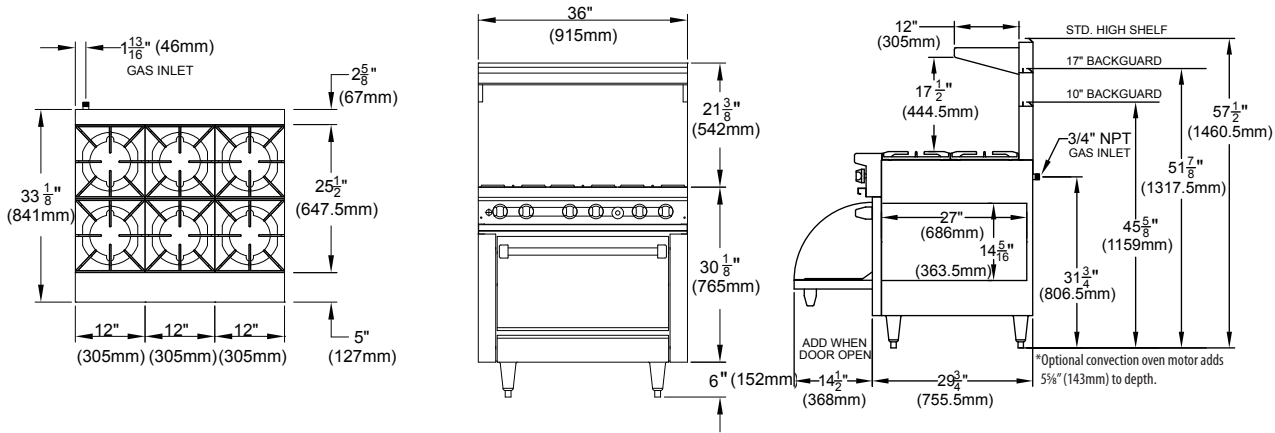

Crated Dimensions			
Width	Depth	Height	Cubic Feet
45" (1143mm)	45" (1143mm)	41 1/4" (1048mm)	37

Entry Clearance	
Crated	Uncrated
46" (1168mm)	34" (864mm)

Uncrated Exterior Dimensions			Oven Interior Dimensions			Installation Clearances From Combustibles		
Height (w/highshelf) 57 1/2" (1461mm)	Width 36" (914.5mm)	Depth* 33 1/8" (841mm)	Height 14 5/16" (364mm)	Width 26 1/4" (667mm)	Depth 27" (686mm)	Open Burner	Sides 12" (305mm)	Rear 6" (152.5mm)
						Griddle, Hot Top, Char Broiler	6" (152.5mm)	6" (152.5mm)

Input Rating Per Burner Type (Natural and Propane Gas)										Operating Manifold Gas Pressure			
Open		Griddle		Char Broiler		Hot Top		Oven		Natural		Propane	
BTU	kW	BTU	kW	BTU	kW	BTU	kW	BTU	kW	"WC	mbar	"WC	mbar
30,000	8.79	20,000	5.86	30,000	8.79	20,000	5.86	35,000	10.25	5	12.45	10	24.9

Model Number	Description	Total BTU/Hr	Gross Weight	
			Lbs.	Kg
TMDS36-6-1	Six open burners with 26" oven	215,000	535	243
TMDS36-6-0	Six open burners with storage base	180,000	505	230
TMDS36-12G-4-1	12" griddle, four open burners with 26" oven	175,000	550	250
TMDS36-12G-4-0	12" griddle, four open burners with storage base	140,000	535	243
TMDS36-24G-2-1	24" griddle, two open burners with 26" oven	135,000	590	268
TMDS36-24G-2-0	24" griddle, two open burners with storage base	100,000	565	257
TMDS36-36G-1	36" griddle with 26" oven	95,000	610	277
TMDS36-36G-0	36" griddle with storage base	60,000	585	266

NOTE: Add suffix "N" for natural gas, and "L" for propane.

Installation Notes

This product is NOT approved for residential use.
Please advise us of installation over 2000ft. (610m) altitude.
Installation clearance reduction applies only where local codes permit.
All Therma-Tek products are covered by a one year limited parts and labor warranty.
A detailed warranty is included with the appliance or is available upon request.
Installation and/or operation by other than manufacturer's recommendations may void warranty.
Because of continuing product improvement, these specifications are subject to change without notice.

