



STAR-MAX™ ELECTRIC GRIDDLES

Models 515TGD, 524TGD, 536TGD & 548TGD

Features/Benefits:

- ★ Star-Max™ Electric Griddles provide superior cooking performance and reliability.
- ★ Ultra-smooth 3/4" polished steel griddle surface provides even heat distribution and fast recovery.
- ★ Available in 15", 24", 36" and 48" widths to meet your space and volume requirements.
- ★ Snap-action thermostatic control from 150°F to 450°F provides quick response to surface temperature change.
- ★ A 4000 watt element every 12" of cooking surface eliminates hot spots and allows for fast recovery.
- ★ Spatula wide 3-1/4" grease trough, grease chute and 4-1/2" high tapered splash guard for easy clean up.
- ★ Large 4-1/2 quart stainless steel grease drawer is standard.
- ★ Heavy-duty 4" legs adjust to match the height of other Star-Max equipment in your line.



Model 536TGD

Applications:

Star-Max™ electric griddles provide precise temperature control and are a perfect addition to any food service operation. Whatever the product, Star-Max™ electric griddles will satisfy your taste for efficient cooking.

Quality Construction:

Star-Max™ electric griddles are constructed with quality and durability in mind. Stainless steel control panel with black polycarbonate trim, stainless steel bull nose front for knob protection, and nickel-plated die-cast legs offer years of easy maintenance and outstanding performance. Double wall construction allows installation within 1" of combustible surface when your space is limited. Griddles operate on 208 or 240 volts and are equipped with a junction box at the rear for making electrical connections.

Warranty:

Star-Max™ electric griddles are covered by Star's one year parts and labor warranty.



Model 548TGD
with Optional Equipment Stand
and Casters





STAR-MAX™ ELECTRIC GRIDDLES

Models 515TGD, 524TGD, 536TGD & 548TGD

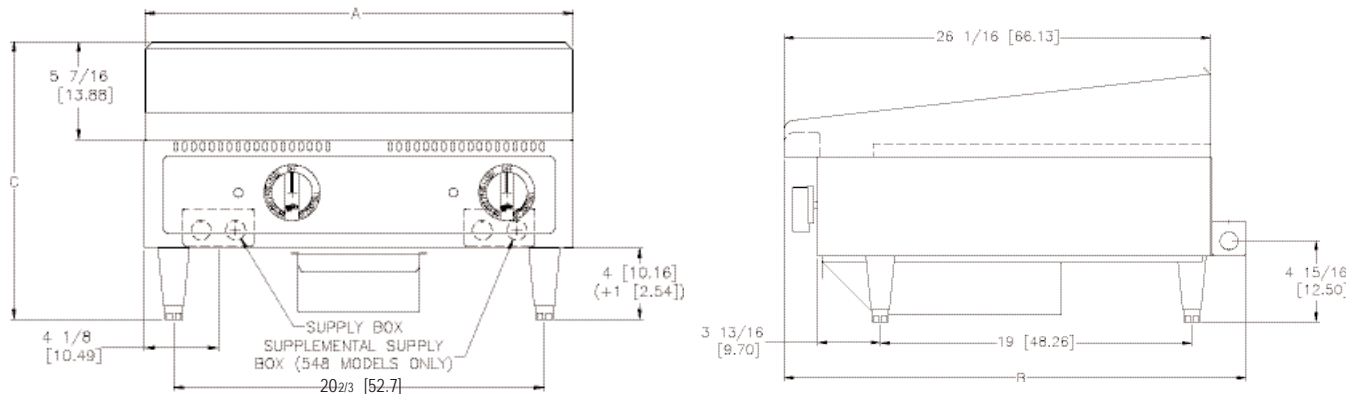

Specifications

Model No.	Dimensions				No. Controls	Grid Area	Plate Thickness Inches (cm)	Weight	
	(A) Width Inches (cm)	(B) Depth Inches (cm)	(C) Height Inches (cm)	(D) Leg Width Inches (cm)				Installed lbs. (kg)	Shipping lbs. (kg)
515TGD	15 (38.1)	27-7/8 (70.8)	15-1/2 (39.4)	12-3/4 (32.39)	1	304 sq. in. 1961.4 sq. cm	3/4 (1.9)	83 (37.6)	125 (56.7)
524TGD	24 (61.0)	27-7/8 (70.8)	15-1/2 (39.4)	20-3/4 (52.71)	2	498 sq. in. 3213.1 sq. cm	3/4 (1.9)	165 (74.8)	175 (79.4)
536TGD	36 (91.4)	27-7/8 (70.8)	15-1/2 (39.4)	32-3/4 (83.19)	3	747 sq. in. 4819.6 sq. cm	3/4 (1.9)	247 (112.0)	262 (118.9)
548TGD	48 (121.9)	27-7/8 (70.8)	15-1/2 (39.4)	44-3/4 (113.67)	4	996 sq. in. 6426.2 sq. cm	3/4 (1.9)	330 (149.7)	350 (158.8)

Electrical Data

Model No.	Rated Wattage		3 Phase Loading KW Per Phase						Nominal Amps Per Line Wire							
	208V	240V	208V			240V			208V-3PH			240V-3PH			208V 1PH	240V 1PH
			X-Y	Y-Z	X-Z	X-Y	Y-Z	X-Z	X	Y	Z	X	Y	Z		
515TGD	3,004	4,000			3			4							14.44	16.66
524TGD	6,008	8,000	3	3		4	4		14.4	25	14.4	16.7	28.9	16.7	28.9	33.3
536TGD	9,012	12,000	3	3	3	4	4	4	25	25	25	28.9	28.9	28.9		
548TGD	12,016	16,000	3	3	6	4	4	8	38.2	25	38.2	44.2	28.9	44.2	57.8	66.7

Typical Specifications

Electric griddles are constructed of stainless steel front panel with black polycarbonate trim and double wall aluminized steel side panels. Griddle plate is 3/4" (1.91 cm) thick highly polished steel with 4-1/2" (11.4 cm) wrap-around stainless steel splash guard. Unit has a 1-3/8" (3.5cm) wide front grease trough with grease chute and 4-1/2 qt.(4.257 L) stainless steel grease drawer. Unit is heated with a 4000 watt incoloy sheath type element every 12" (30.48 cm) of griddle width and is controlled with a snap-action thermostat. Thermostat knob is protected by a stainless steel bull nose front. Units are supplied with 4" (10.16 cm) die cast nickel plated legs that have a 1-3/8" (3.5 cm) adjustment. A junction box is provided for making electrical connections. Units are listed by Underwriters Laboratories, and are NSF and CSA approved. Printed in the U.S.A.

Star Manufacturing International Inc. - 10 Sunnen Drive - P.O. Box 430129 - St. Louis, MO 63143-3800

Phone: (800) 264-7827 - FAX: (800) 264-6666 - www.star-mfg.com