

HOBART701 S Ridge Avenue, Troy, OH 45374
1-888-4HOBART • www.hobartcorp.com**FP400
FOOD PROCESSOR****HOBART****STANDARD FEATURES**

- Gear transmission.
- Anodized aluminum housing.
- Two-speed motor.
- Triple hopper/cover interlock.
- Two stationary front legs and two rear legs with casters for ease of mobility.
- Processes up to 90 lbs. per minute.
- Plates interchangeable with FP350.

ACCESSORIES

- 3- pack plates ($\frac{1}{16}$ " , $\frac{5}{32}$ " slicer plates, $\frac{3}{16}$ " shredder plate and wall rack).
- 6-pack plates (same as 3-pack plus $\frac{3}{8}$ " , $\frac{7}{32}$ " slicer plates, $\frac{3}{8}$ " dicer plate and additional wall rack).
- 3-peg wall rack (designed to hold 3 plates).
- Stainless steel accessory cart.
- Adjustable height stainless steel lug cart.
- Stainless steel pan.
- Plastic pan.
- 41 individual plates available.

MODEL

- FP400-1 (Must also select Feed Hopper Choice)

FEED HOPPER CHOICES

- Manual/Tubular Cylinder (PFD-CYL)
Choose one or both:
 - Manual Push Feed Assembly.
 - Tubular Feeder.
- Bulk Feed Hopper and Cylinder (Complete).

Specifications, Details and Dimensions on Reverse Side.

**FP400 FOOD PROCESSOR**

FP400 FOOD PROCESSOR



701 S Ridge Avenue, Troy, OH 45374
1-888-4HOBART • www.hobartcorp.com

LISTED BY: UNDERWRITERS LABORATORIES AND NSF INTERNATIONAL

SPECIFICATION: 2 H.P. two speed motor, 250/500 rpm, anodized case aluminum housing. Plates are interchangeable with FP350 and are constructed of stainless steel blades with aluminum frames.

ELECTRICAL SPECIFICATIONS: 208-240/60/3, 7.5 amps, 6 foot, 3 conductor power cord (16 AWG). Furnished with NEMA L15-20P locking type plug.

WEIGHT: Net Lbs.: Machine 119 lb., Feed Cylinder 13 lb., Manual Push Feeder 11 lb., Continuous Feed Hopper 27 lb.

DETAILS AND DIMENSIONS

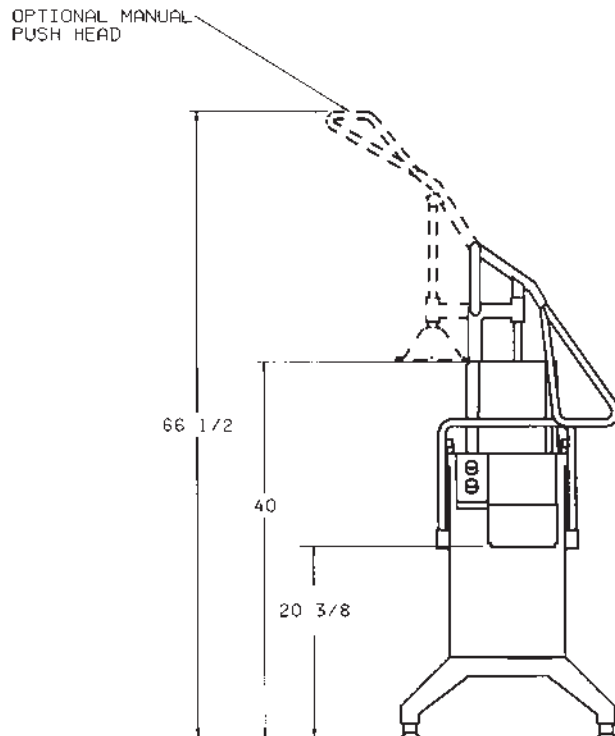
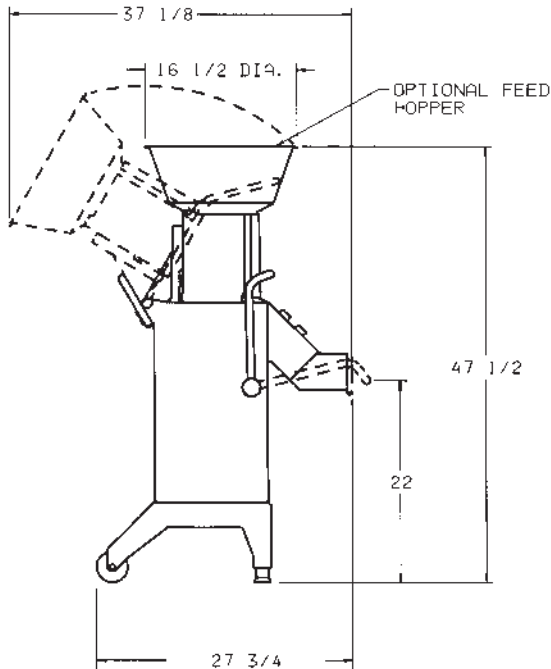
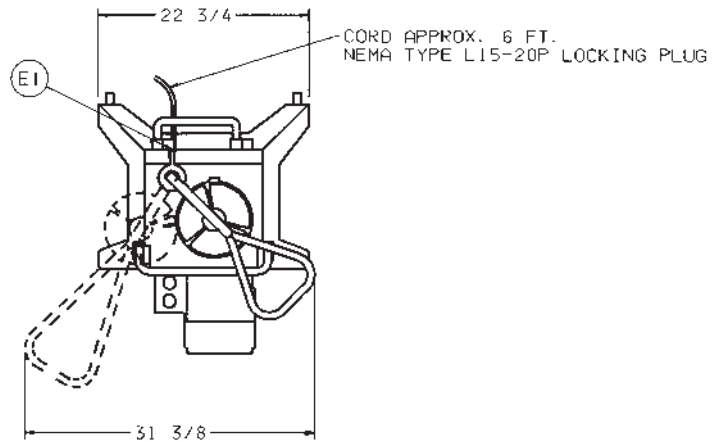
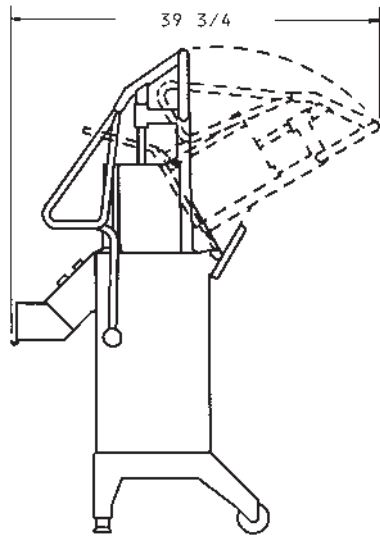

As continued product improvement is a policy of Hobart, specifications are subject to change without notice.