

HOBART701 S Ridge Avenue, Troy, OH 45374
1-888-4HOBART • www.hobartcorp.com**84186
FOOD CUTTER****HOBART****STANDARD FEATURES**

- 1 H.P. Motor
- 18" Stainless Steel Bowl
- One-piece Burnished Aluminum Housing
- 1725 RPM Knife Rotation
- Bowl Cover Safety Interlock
- 20 RPM Bowl Rotation
- Double Cutlery Grade Stainless Steel Knives
- Pull/Push On/Off Switch
- 3" Stainless Steel Legs With Rubber Feet
- 6' Flexible Cord and Plug

OPTIONS

- #12 Attachment Hub
- Deluxe Bowl Cover (with attachment hub only)

ACCESSORIES

- Vegetable Slicer
- Meat Chopper Attachment

MODELS

- 84186 – Food Cutter with 18" Stainless Steel Bowl, Double Cutlery Grade Stainless Steel Knives with Stainless Steel Knife Comb and 3" Stainless Steel Legs with Rubber Feet
- 84186C – Maximum Security Correctional Package (115/60/1, 230/60/1 and 208/60/3 with attachment hub only)

Specifications, Details and Dimensions on Reverse Side

**84186 FOOD CUTTER**

84186 FOOD CUTTER

HOBART

701 S Ridge Avenue, Troy, OH 45374
1-888-4HOBART • www.hobartcorp.com

SOLUTIONS/BENEFITS

1 H.P. Motor

Durability, Reliability

- Heavy-duty to meet the most demanding operations

Bowl Cover Safety Interlock

Safety

- Machine cannot be turned on until the bowl cover is locked down into position
- Bowl cover cannot be raised with the switch in the "ON" position

One-piece Burnished Aluminum Housing

Durability, Sanitation

- One-piece base has no cracks or crevices to allow food product to hide

Removable Bowl Cover, Knives and Bowl Without the Use of Tools

Ease of Cleaning, Ease of Use

- Easily removed to be taken to three compartment sink for thorough cleaning
- No tools needed to remove means less time and labor involved

Double Cutlery Grade Stainless Steel Knives

Durability, Performance

- Reduces food products to a uniformly small particle size for salads, spreads, bread crumbs and other imaginative recipes
- Holds an edge longer resulting in fewer sharpenings

ELECTRICAL: 115/60/1, 230/60/1, 208/60/3 and 460/60/3 – U L Listed. Also available in 230/50/1 and 200/50/3 – Not submitted for U L Listing.

SWITCH: On/off switch is mechanically interlocked with bowl cover so that the switch cannot be operated unless bowl cover is locked down in position. On/off switch actuates a magnetic contactor.

CORD AND PLUG: 6 foot flexible cord with plug per NEMA configuration. Export models will be supplied with I.E.C. cord without plug.

BOWL: 18" inside diameter. Made of single piece of stainless steel, is easily removed for cleaning. Rotates at 20 RPM.

BOWL COVER: One-piece burnished aluminum casting, carefully fitted to the top of the bowl. It can be lifted to remove material from the bowl and can be removed for easy cleaning. Optional deluxe bowl cover available (with attachment hub only).

KNIVES: Rotate at 1725 RPM. The blades (made of special cutlery grade stainless steel) are secured to a hub as a unit, which may be removed from the knife shaft without change of knife clearance adjustment. Stainless steel knife comb included.

BASE: One-piece burnished aluminum casting with plated steel bottom cover (total enclosure).

STANDARD EQUIPMENT: Consists of Food Cutter with 18" stainless steel bowl, cutlery grade stainless steel knives with stainless steel knife comb and 3" stainless steel legs with rubber feet.

ATTACHMENT HUB: Speed – 256 RPM. Accommodates all Hobart No. 12 attachments.

ACCESSORIES: Vegetable Slicer and Meat Chopper Attachment.

WEIGHTS: Net – 140 lbs.; Shipping – 185 lbs.

WARRANTY: Unit has a full one-year warranty on parts, labor and mileage against manufacturer's defects.

SPECIFICATIONS

MOTOR: 1 H.P., with ball bearings. Single-phase is capacitor-start, induction-run type. Three-phase is polyphase squirrel-cage, induction-run type.

DETAILS AND DIMENSIONS

WARNING

ELECTRICAL AND GROUNDING CONNECTIONS MUST COMPLY WITH APPLICABLE PORTIONS OF THE NATIONAL ELECTRICAL CODE AND/OR OTHER LOCAL ELECTRICAL CODES

NOTE: IF THIS MACHINE IS TO BE INSTALLED WITHOUT LEGS, THE BASE MUST BE SEALED TO THE SUPPORTING SURFACE FOR N.S.F. APPROVAL

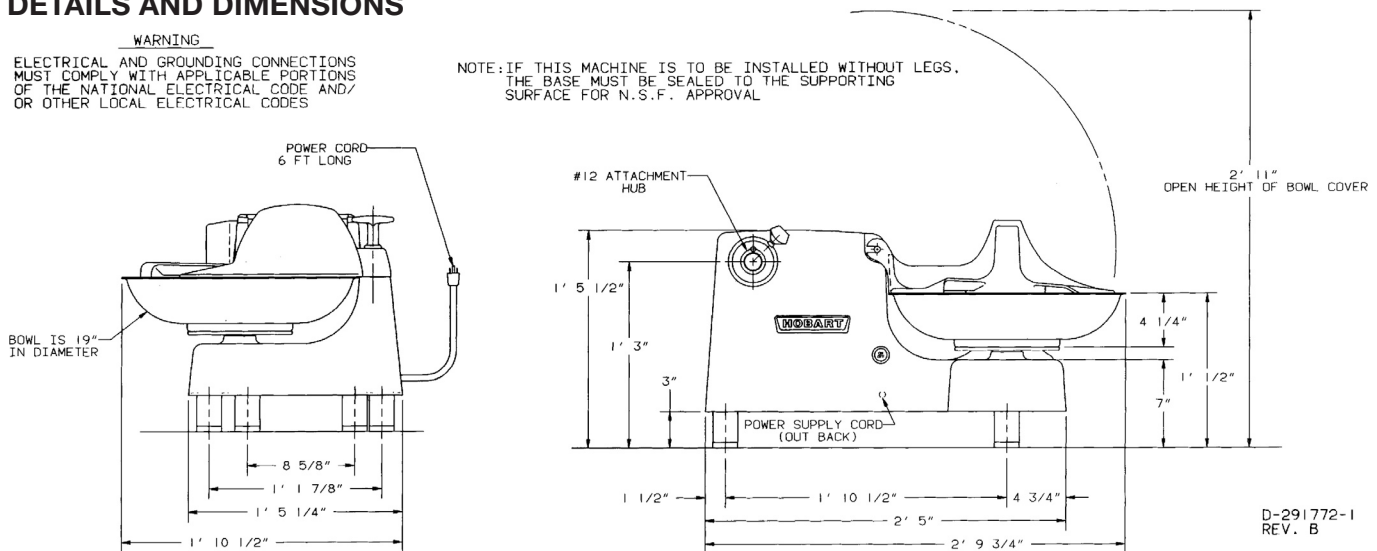

As continued product improvement is a policy of Hobart, specifications are subject to change without notice.