



Since 1911

# Gas & Electric Fryers, The FRY-SAVER<sup>®</sup>

Heavy Duty, High Performance



Stainless Steel Construction

Stainless Steel Fry Tank



Countertop Fryers Gas and Electric

Keeps Oil at Peak Quality



The FRY-SAVER<sup>®</sup> - Oil Filtration System



Since 1911

# Heavy Duty Floor Model Electric Fryers - 40 lb. and 65 lb.

The Cecilware Electric & Gas Floor Model fryers are designed with the foodservice operator in mind. We have built an



### Features

- ✓ **Economical To Operate** - Maximum efficiency with a balanced electrical load.
- ✓ **Mechanical Temperature Controls**
- ✓ **Trouble Free, Low Watt Density, Fixed Elements**
- ✓ **High Energy Incoloy Elements** - provide fast recovery.
- ✓ **Robertshaw High Limit and Automatic Temperature Controls** - insure accurate, safe fryer operation. Conserve energy and save money.
- ✓ **Melt Cycle Controls** - standard on all models.
- ✓ **Oversized, Full-flow 1.25" Drain Valve** - makes draining effortless.
- ✓ **Tough Unibody Construction**
- ✓ **All Controls Are Easy To Service and Accessible From the Front of the Fryer.**
- ✓ **Options:** Locking & regular casters, single fry baskets, banking strips

Model #	Tank	Fat Capacity	Overall Depth	Width	Ship Weight	Electrical	
						1 Phase	3 Phase
EFP-40*	Mild Steel	40 lbs.	31"	15½"	140 lbs.	208V,50A	
EFS-40*	Stainless Steel					208V,86.5A / 240V,75A	220V,48A / 380V,28A / 240V,44A / 415V,25A
EFP-65**	Mild Steel	65 lbs.	35"	20"	200 lbs.	208V,58A	
EFS-65**	Stainless Steel					208V,100A / 240V,87.5A	220V,55A / 380V,32A / 240V,51A / 415V,29A

Working Height: 35" Overall Height: 44½" Minimum Fat Capacity: \* 55 lbs. \*\* 102 lbs. Specify voltage and phase  
 40 lb. Fryer Basket Size: 12½" x 6½" x 5½"; Use Basket # V184A 65 lb. Fryer Basket size: 16¾" x 8¾" x 6"; Use Basket # V180A  
 40 lb. Fryer Foam Area: 13½" x 22" 65 lb. Fryer Foam Area: 18¾" x 28"  
 40 lb. Fryer: 18 KW 65 lb. Fryer: 21 KW  
 Door: Stainless Steel; Body: Stainless Steel except: FMP-40BSS - Enamel

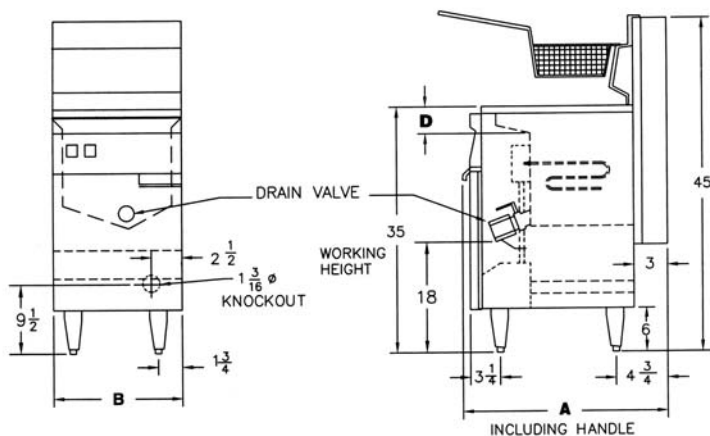
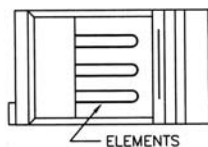

### Electric & Gas Fryer

Model	A	B
40 lb.	31"	15½"
65 lb.	35½"	20"

### Floor Model Fryer

Part #	Fryer Type	Depth
V174P	40 lb. gas / electric	13¾"
V180P	65 lb. gas / electric	16¾"

"P" Plasticized handles Front hook placement

# Heavy Duty Floor Model Gas Fryers - 40 lb. and 65 lb.

Model Fryers were designed with the economical, efficient and hard working fryer.

When you need performance, you can depend on Cecilware Heavy Duty Gas Fryers to do the job.

## Features

- ✓ Heavy Duty Stainless Steel Unibody Construction - for long life.
- ✓ Heavy Duty Stainless Steel Heat Exchangers - for maximum heat transfer.
- ✓ Heavy Duty Cast Iron Burners
- ✓ Oversized, Full-flow 1.25" Drain Valve - makes draining effortless.
- ✓ Automatic Temperature Controls - standard.
- ✓ Large Foam Area
- ✓ Super Fast Heat-up & Recovery
- ✓ Includes Two Fry Baskets and Crumb Screen
- ✓ Options: Locking and regular casters, single fry basket, banking strips



Model #	Tank	Fat Capacity	Overall Depth	Width	BTU/Hr.	Burner Tubes	Ship Weight
FMP403-HP*	Mild Steel	40 lbs.	31"	15½"	110,000 Nat 100,000 LP	3	190 lbs.
FMS403-HP*	Stainless Steel						
FMP-40**	Mild Steel	40 lbs.	31"	15½"	115,000	4	200 lbs.
FMP-40BSS**	Mild Steel						
FMS-40**	Stainless Steel	65 lbs.	35¼"	20"	140,000	5	265 lbs.
FMP-65***	Mild Steel						
FMS-65***	Stainless Steel						

Minimum Fat Capacity: \* 49 lbs., \*\*41 lbs., \*\*\*79 lbs. Specify Natural or LP Gas; Working Height: 35" Overall Height: 44½"

40 lb. Fryer Basket Size: 13¼" x 6½" x 6"; Use Basket # V174A 40 lb. Fryer Foam Area: 13½" x 22"

65 lb. Fryer Basket Size: 16¾" x 8¾" x 6"; Use Basket # V180A 65 lb. Fryer Foam Area: 18¼" x 28"

Door: Stainless Steel; Body: Stainless Steel except: FMP-40BSS, FMS403HPBSS - Enamel sides

## Dimensions

C	D
- - -	4½"
17"	5¼"

## Baskets

Width	Height	Weight
6½"	6"	3 lbs.
8¾"	6"	7 lbs.

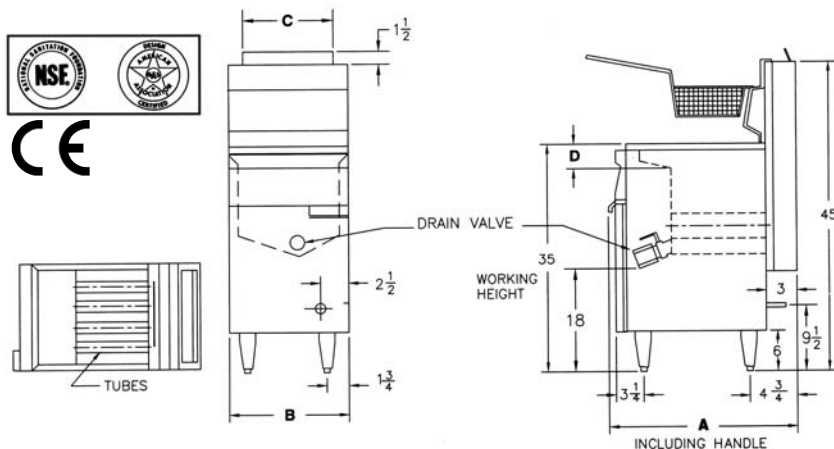

# Counter Top Gas Fryers

## Features

- ✓ Heavy duty 100% stainless steel construction for long life.
- ✓ 18 gauge Stainless Steel fry tank.
- ✓ Automatic temperature controls.
- ✓ Includes two fry baskets, crumb screen, and pressure regulator.
- ✓ Ball type slanted drain valve for fast draining.
- ✓ Basso Safety Pilot with high-limit control.
- ✓ GF-10 has a flat bottom, GF-16 and GF-28 are tube fired.
- ✓ 4" legs optional.



Model #	Fat Capacity	Depth	BTU/Hr Nat.; LP	Ship Weight	Use Fry Baskets
GF-10	13 lbs.	20½"	26,000; 26,000	53 lbs.	V091A/V092A
GF-16	18 lbs.	21¾"	22,500; 18,000	60 lbs.	V091A/V092A
GF-28	28 lbs.	22"	45,000; 38,000	91 lbs.	V094A/V095A

Specify Natural or LP Gas    **Width:** 12¼" GF28: 18¼"    **Height:** 17¼" GF10: 14½"

# Counter Top Electric Fryers

Removable Stainless Steel Tank

Automatic Temperature Controls

## Features

- ✓ Heavy duty 100% stainless steel construction for long life.
- ✓ The EL120 can plug in anywhere.
- ✓ Heavy duty, high speed elements.
- ✓ Automatic temperature controls.
- ✓ Includes two fry baskets.



Model #	Fat Capacity	Width	Depth	Height	Electrical	Ship Weight
EL-120	15 lbs.	12"	19½"	8¼"	120V, 18KW, 15A	29 lbs.
EL-170	Same as EL-120 with 4" legs					
EL-250	15 lbs.	12"	19½"	8¼"	240V, 5.5KW, 22.9A 208V, 4.2KW, 20.2A	29 lbs.
EL-270	Same as EL-250 with 4" legs					
EL-310*	45 lbs.	18"	21"	11½"	240V, 5.5KW, 22.9A 208V, 5.5KW, 26.4A	45 lbs.
ELT-500	60 lbs.	25½"	20½"	18½"	240V, 11KW, 46A 208V, 8.4KW, 40A	60 lbs.

\* Specify voltage. 1 phase only. EL-120/170 and EL-250/270 line cord included

Use Fry Baskets: V091A and V092A except for EL310 use V077A and V078A

## Counter Top Fry Baskets

Part #	Fryer Type	Hook Placement	Depth	Width	Height
V006A	10 lb. gas	Front	8¾"	3½"	4½"
V091A	13, 18 lb. gas, 15 lb. electric	Right	10¾"	3⅜"	3¾"
V092A		Left			
V077A	20 lb. electric	Right	10⅞"	3½"	4⅞"
V078A		Left			
V094A	28 lb. gas	Right	10⅞"	5⅝"	4¾"
V095A		Left			



# FRY-SAVER<sup>®</sup>

The Only Filtration System That Doubles the Life of Cooking Oil!



Automatic  
Reversible Pump

Compact Design

## Why Leading Chain Store Restaurants Prefer the FRY-SAVER<sup>®</sup>

No  
Diatomaceous  
Earth  
or Chemicals  
Needed!

- ✓ **Keeps Oil At Peak Quality** - Improves the taste of fried foods by removing contaminants > 3 microns.
- ✓ **Reduces Oil Cost To Keep Profits High** - Doubles the life of oil.
- ✓ **Super Fast Filtration Process** - Processes 3 ½ gallons of oil in 1 minute.
- ✓ **Safe, Automatic, Reversible Pump** - No pouring, spilling or spattering. Oil is pumped into the completely enclosed unit, thoroughly filtered, and at the flip of a switch pumped back, absolutely clean.

# Reasons FRY-SAVER® Works Better Than Other Filtration Systems

- ✓ Pleated filter design provides 15 times more filtering area than other filters. Long life FRY-SAVER® pleated cartridge filters are replaced only when pleats become full.
- ✓ Does not require Diatomaceous Earth or other harsh chemicals that can leave residue in oil.
- ✓ The only filter system that removes microscopic oil-killing contaminants.
- ✓ Filter Cartridge and Pre-Filter Paper - filters and cleans up to 1,500 lbs. of oil or fat.

Oil Savings Calculations - Filtering Once Per Day				
	Not Filtering	Cecilware FRY-SAVER®	Leading Competitor	Insert Your Figures
<b>A</b> Lbs. of Oil Used Per Day	40	40	40	
<b>B</b> Life of Oil		2 (Doubles)	1.5	
<b>C</b> Days Per Year	365	365	365	
<b>D</b> Total lbs. of Oil Used Per Year $(A \times C) \div B$	14,600	7,300	9,733	$(A \times C) \div B$
<b>E</b> Price of oil per lb.	\$ 0.46	\$0.46	\$ 0.46	
<b>F</b> Annual Oil Expense $(D \times E)$	<b>\$ 6,716</b>	<b>\$ 3,358</b>	<b>\$4,477</b>	$(D \times E)$
<b>G</b> Diatomaceous Earth	-	(not needed)	\$406	
<b>H</b> Filter Paper	-	\$274	\$314	
<b>I</b> Filter Cartridges	-	\$375	-	
<b>J</b> Adjusted Annual Oil Expense $(F+G+H+I)$	<b>\$ 6,716</b>	<b>\$ 3,632</b>	<b>\$ 5,197</b>	$(F+G+H+I)$
<b>Savings vs. Not Filtering</b>		<b>\$ 3,084</b>		
<b>Savings vs. Leading Competitor</b>		<b>\$ 1,565</b>		



## Accessories

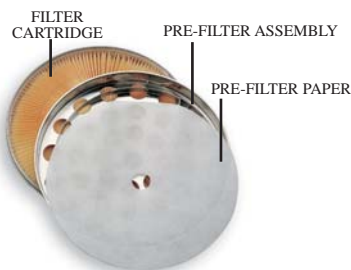

Part #	Description
20000 (F-101)	Filter Cartridges (1 dozen / carton)
20003	Filter Cartridges (3 / pack)
20215 (F-201)	Stainless Steel Pre-Filter Assembly
20220 (F-202)	Pre-Filter Paper For F-201 (150 / carton)
20230	Large Casters (4 / Set)
20240	Stabilizing "Wings" For Large Casters (Model F-150 only)

Model #	Capacity	Height	Pump Capacity	Ship Weight
F-60	60 lbs. (8 gals.)	17"	3.5 gal. / Min.	85 lbs.
F-100	120 lbs. (16 gals.)	33"		95 lbs.
F-150	150 lbs. (20 gals.)	40"		105 lbs.

**Electrical:** 120 volts, 60 cycles, 5.5 amps  
**Motor:** 1/4 hp; **Diameter:** 17"  
 When 220 volts, 50 cycle motor is furnished; the above model numbers will carry the designation "NUL"

Specifications subject to change without prior notice

Cecilware Corporation • 43-05 20th Avenue • Long Island City, NY 11105  
 Tel: 800.935.2211 • 718.932.1414 • Fax 718.932.7860 • www.cecilware.com

