



## GRIDDLES & CHARBROILERS

### AHP SERIES COUNTER MODEL ACHIEVER HOTPLATE



Model AHP424



- AHP212** 12" wide
- AHP424** 24" wide
- AHP636** 36" wide
- AHP848** 48" wide

#### STANDARD FEATURES

- Stainless steel sides and control panel.
- Full width pull out crumb tray.
- Heavy duty cast iron top grates.
- 30,000 BTU/hr open burners with lift-off heads.
- Standing pilot ignition system.
- One infinite heat control valve for each burner.
- 4" adjustable legs.
- 3/4" rear gas connection and gas pressure regulator.
- One year limited parts and labor warranty.

#### OPTIONAL FEATURES

- Step-up burners. Rear burners elevated 4".
- Cutting board.
- Condiment rail.
- Plate rail.
- Stainless steel stand with undershelf and casters.

#### SPECIFICATIONS

##### Exterior Dimensions:

\_\_\_\_\_ "wide x 33" deep x 12<sup>3</sup>/<sub>8</sub>" working height on 4" adjustable legs.

CSA design certified. NSF listed.

**SPECIFY TYPE OF GAS WHEN ORDERING.**  
**SPECIFY ALTITUDE WHEN ABOVE 3,999 FT.**



# AHP SERIES

## COUNTER MODEL ACHIEVER HOTPLATE

### INSTALLATION INSTRUCTIONS

1. A gas pressure regulator sized for this unit is included. Natural Gas 5.0" W.C. Propane Gas 10.0" W.C.
2. An adequate ventilation system is required for commercial cooking equipment. Information may be obtained by writing to the National Fire Protection Association, 1 Batterymarch Park, Quincy, MA 02169, www.NFPA.org. When writing refer to NFPA No. 96.
3. These units are manufactured for installation in accordance with National Fuel Gas Code, ANSI-Z223.1/NFPA #54 (latest edition). Copies may be obtained from The American Gas Association Accredited Standards Committee Z223, @ 400 N. Capital St.

NW, Washington, DC 20001, or the Secretary Standards Council, NFPA, 1 Batterymarch Park Quincy, MA 02169-7471.

**NOTE: In the Commonwealth of Massachusetts**

All gas appliances vented through a ventilation hood or exhaust system equipped with a damper or with a power means of exhaust shall comply with 248 CMR.

4. Equipment clearance:
 

	Combustible	Non-Combustible
Rear	6"	0"
Sides	6"	0"
5. This appliance is intended for commercial installation only and is not intended for home use.

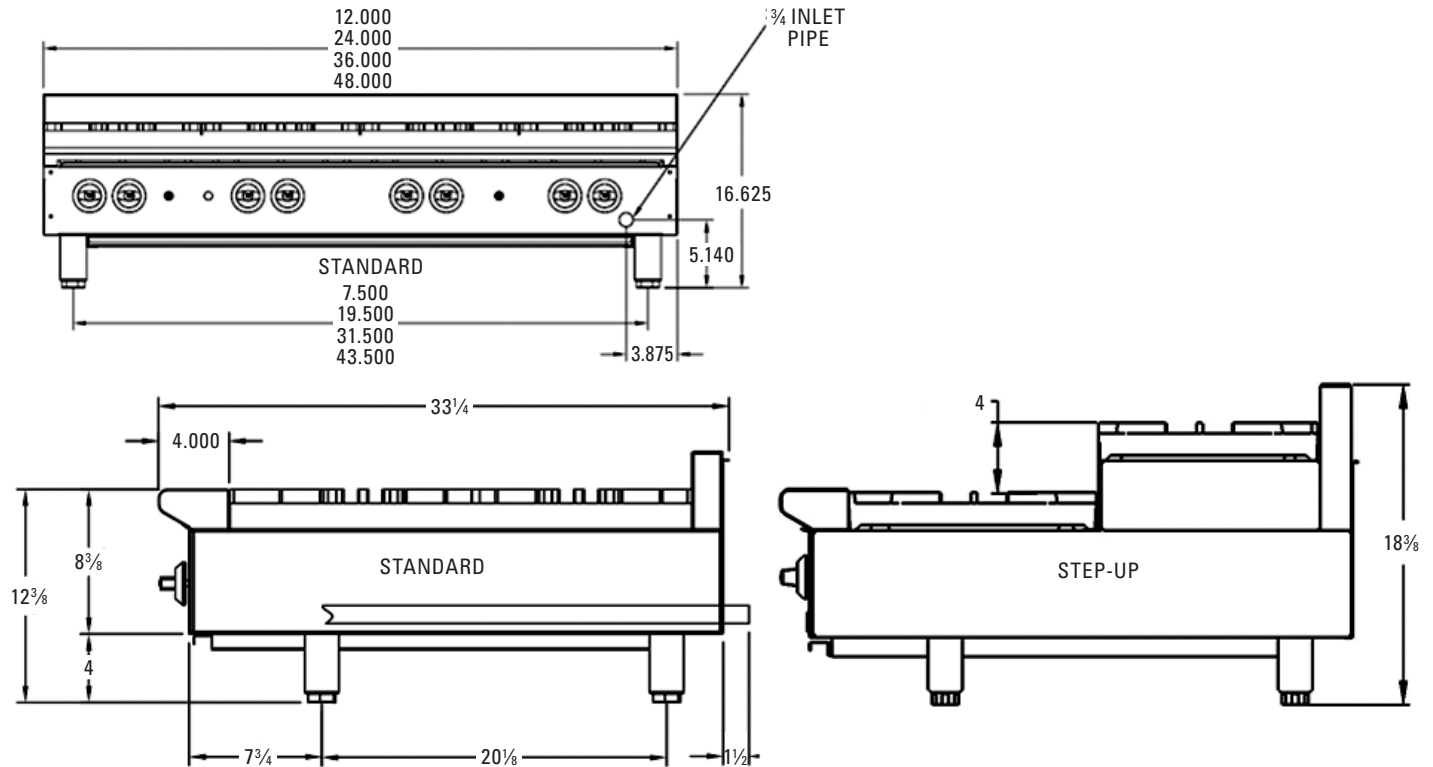

MODEL	WIDTH	DEPTH	OVERALL HEIGHT	WORKING HEIGHT*	# BURNERS	TOTAL BTU/HR	APPROX SHIP WT (LB/KG)
AHP212	12"	33"	16 <sup>5</sup> / <sub>8</sub> "	12 <sup>3</sup> / <sub>8</sub> "	2	60,000	95 lbs./43 kg
AHP424	24"				4	120,000	165 lbs./74 kg
AHP636	36"				6	180,000	265 lbs./119 kg
AHP848	48"				8	240,000	310 lbs./140 kg