



**TRUE MANUFACTURING CO., INC.**  
**U.S.A. FOODSERVICE DIVISION**

2001 East Terra Lane • O'Fallon, Missouri 63366-4434 • (636)240-2400  
 Fax (636)272-2408 • Toll Free (800)325-6152 • Intl Fax# (001)636-272-7546  
 Parts Dept. (800)424-TRUE • Parts Dept. Fax# (636)272-9471 • www.truemfg.com

Project Name: \_\_\_\_\_

Location: \_\_\_\_\_

Item #: \_\_\_\_\_ Qty: \_\_\_\_\_

Model #: \_\_\_\_\_

A/A #

SIS #

Model:

**GDM-33SSL-56-HC-LD**

## Glass Door Merchandiser:

*Slide Door Lower Height Narrow Depth Refrigerator with Hydrocarbon Refrigerant and LED Lighting*



## GDM-33SSL-56-HC-LD

- ▶ The world's #1 manufacturer of glass door merchandisers.
- ▶ Lower profile on convenience store coolers allows extra visibility throughout store. Makes gondola and center store placement possible.
- ▶ Factory engineered, self-contained, capillary tube system using environmentally friendly R290 hydro carbon refrigerant that has zero (0) ozone depletion potential (ODP), & three (3) global warming potential (GWP).
- ▶ Energy efficient, factory balanced, refrigeration system holds 33°F to 38°F (5°C to 3.3°C).
- ▶ Exterior - non-peel or chip black powder coated cold rolled steel; durable and permanent.
- ▶ Interior - attractive, NSF approved, white aluminum interior liner with stainless steel floor.
- ▶ Self closing doors. Counter-balanced weight system for smooth, even, positive closing.
- ▶ "Low-E", double pane thermal insulated glass door assemblies with mitered plastic channel frames. The latest in energy efficient technology.
- ▶ LED interior lighting provides more even lighting throughout the cabinet. Safety shielded.
- ▶ Entire cabinet structure is foamed-in-place using Ecomate. A high density, polyurethane insulation that has zero ozone depletion potential (ODP) and zero global warming potential (GWP).

### Bottom mounted units feature

- ▶ "No stoop" lower shelf to maximize product visibility.
- ▶ Storage on top of cabinet.
- ▶ Easily accessible condenser coil for cleaning.

## ROUGH-IN DATA

Specifications subject to change without notice.  
 Chart dimensions rounded up to the nearest 1/8" (millimeters rounded up to next whole number).

| Model              | Doors | Shelves | Cabinet Dimensions (inches) (mm) |           |            | HP         | Voltage  | Amps       | NEMA Config. | Cord Length (total ft.) (total m) | Crated Weight (lbs.) (kg) |
|--------------------|-------|---------|----------------------------------|-----------|------------|------------|----------|------------|--------------|-----------------------------------|---------------------------|
|                    |       |         | W                                | D†        | H          |            |          |            |              |                                   |                           |
| GDM-33SSL-56-HC-LD | 2     | 4       | 36<br>915                        | 18<br>458 | 56<br>1423 | 1/8<br>N/A | 115/60/1 | 3.0<br>N/A | 5-15P        | 9<br>2.74                         | 235<br>107                |

† Depth does not include 3/8" (23 mm) for door handles.



APPROVALS:

AVAILABLE AT:

Model:  
**GDM-33SSL-56-HC-LD**

**Glass Door Merchandiser:**  
*Slide Door Lower Height Narrow Depth Refrigerator  
with Hydrocarbon Refrigerant and LED Lighting*



**STANDARD FEATURES**

**DESIGN**

- True's commitment to using the highest quality materials and oversized refrigeration systems provides the user with colder product temperatures, and lower utility costs in an attractive merchandiser that brilliantly displays packaged food and beverages.

**REFRIGERATION SYSTEM**

- Factory engineered, self-contained, capillary tube system using environmentally friendly R290 hydrocarbon refrigerant that has zero (0) ozone depletion potential (ODP), & three (3) global warming potential (GWP).
- High capacity, factory balanced refrigeration system that maintains cabinet temperatures of 33°F to 38°F (5°C to 3.3°C) for the best in food preservation.
- State of the art, electronically commutated evaporator and condenser fan motors. ECM motors operate at higher peak efficiencies and move a more consistent volume of air which produces less heat, reduces energy consumption and provides greater motor reliability.
- Bottom mounted condensing unit positioned for easy maintenance. "No stoop" lower shelf maximizes visibility by raising merchandised product to higher level.

**CABINET CONSTRUCTION**

- Exterior - non-peel or chip black powder coated cold rolled steel; durable and permanent.

- Interior - attractive, NSF approved, white aluminum liner with stainless steel floor.
- Insulation - entire cabinet structure is foamed-in-place using a high density, polyurethane insulation that has zero ozone depletion potential (ODP) and zero global warming potential (GWP).
- Welded, heavy duty steel frame rail, black powder coated for corrosion protection.
- Frame rail fitted with recessed swivel castors and leg levelers.
- Door sign decal. Variety of decal options available.

**DOORS**

- "Low-E", double pane thermal insulated glass door assemblies with mitered plastic channel frames. The latest in energy efficient technology.
- Each door fitted with 12" (305 mm) long handle.
- Self closing doors. Counter-balanced weight system for smooth, even, positive closing.

**SHELVING**

- Four (4) adjustable, heavy duty PVC coated wire shelves 31 3/4"L x 11 3/4"D (807 mm x 299 mm). Four (4) chrome plated shelf clips included per shelf.
- Shelf support pilasters made of same material as cabinet interior; shelves are adjustable on 1/2" (13 mm) increments.

**LIGHTING**

- LED interior lighting provides more even lighting throughout the cabinet. Safety shielded.

**MODEL FEATURES**

- Evaporator is epoxy coated to eliminate the potential of corrosion.
- See our website [www.truemfg.com](http://www.truemfg.com) for latest color and sign offerings.
- Convenient clean-out drain built in cabinet floor.
- Wicking Kit.
- Listed under NSF/ANSI Standard 7 for the storage and/or display of packaged or bottled product.

**ELECTRICAL**

- Unit completely pre-wired at factory and ready for final connection to a 115/60/1 phase, 15 amp dedicated outlet. Cord and plug set included.



115/60/1  
NEMA-5-15R

**OPTIONAL FEATURES/ACCESSORIES**

Upcharge and lead times may apply.

- White exterior.
- Black aluminum interior liner with black shelving.
- 6" (153 mm) standard legs.
- 6" (153 mm) seismic/flanged legs.
- 2 1/2" (64 mm) diameter castors.
- Additional shelves.
- Barrel lock (factory installed).
- Ratchet locks.

**PLAN VIEW**

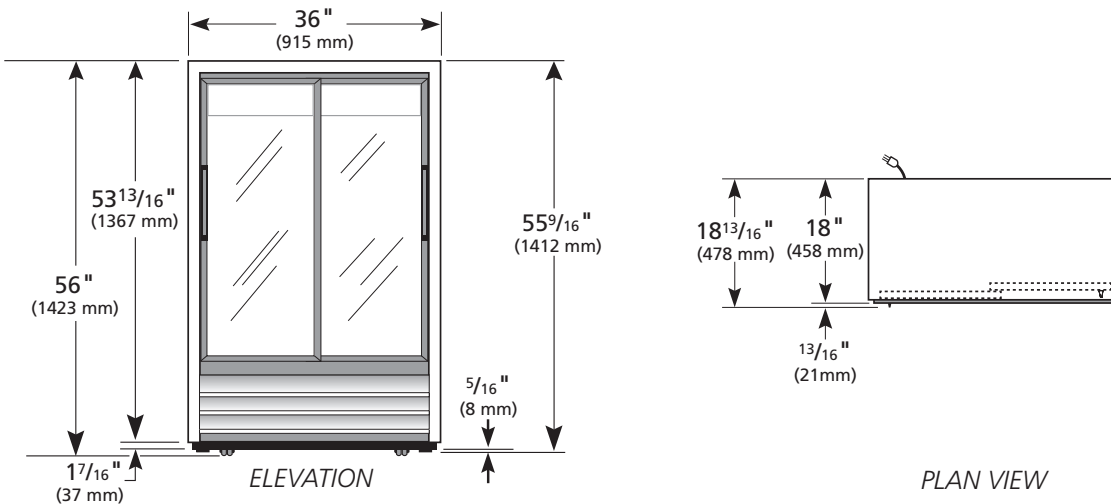

**WARRANTY**  
 Three year warranty on all parts and labor and an additional 2 year warranty on compressor. (U.S.A. only)

METRIC DIMENSIONS ROUNDED UP TO THE NEAREST WHOLE MILLIMETER  
 SPECIFICATIONS SUBJECT TO CHANGE WITHOUT NOTICE



|                    |           |       |      |    |      |
|--------------------|-----------|-------|------|----|------|
| Model              | Elevation | Right | Plan | 3D | Back |
| GDM-33SSL-56-HC-LD |           |       |      |    |      |

**TRUE MANUFACTURING CO., INC.**