

5" 1ST - Pop In Casters

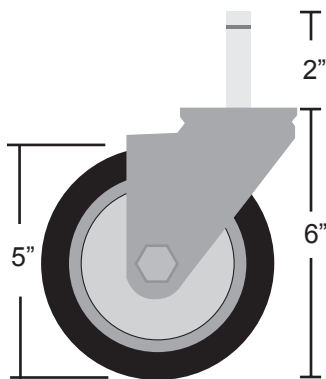

5" Part #	NSF	Wheel Material	Brake	Weight Capacity
5SBR-1ST-PLY	✓	POLYURETHANE		300#
5SBR-1ST-PLY-TLB	✓	POLYURETHANE	Top Lock Brake	300#
5SBR-1ST-HR	✓	HARD RUBBER		300#
5SBR-1ST-HR-TLB	✓	HARD RUBBER	Top Lock Brake	300#
5SBR-1ST-GR	✓	GRAY RUBBER		250#
5SBR-1ST-GR-TLB	✓	GRAY RUBBER	Top Lock Brake	250#
5SBR-1ST-LDP	✓	POLYOLEFIN		300#
5SBR-1ST-LDP-TLB	✓	POLYOLEFIN	Top Lock Brake	300#
5SBR-1ST-PH	✓	PHENOLIC		350#
5SBR-1ST-PH-TLB	✓	PHENOLIC	Top Lock Brake	350#

CALL FOR PRICING

4" 1ST - Pop In Casters

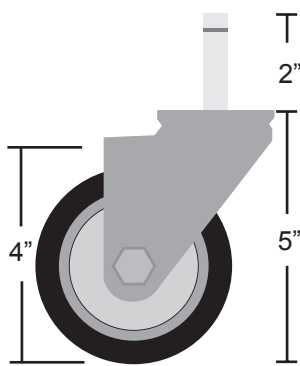

4" Part #	NSF	Wheel Material	Brake	Weight Capacity
4SBR-1ST-PLY	✓	POLYURETHANE		300#
4SBR-1ST-PLY-TLB	✓	POLYURETHANE	Top Lock Brake	300#
4SBR-1ST-HR	✓	HARD RUBBER		300#
4SBR-1ST-HR-TLB	✓	HARD RUBBER	Top Lock Brake	300#
4SBR-1ST-GR	✓	GRAY RUBBER		250#
4SBR-1ST-GR-TLB	✓	GRAY RUBBER	Top Lock Brake	250#
4SBR-1ST-LDP	✓	POLYOLEFIN		300#
4SBR-1ST-LDP-TLB	✓	POLYOLEFIN	Top Lock Brake	300#
4SBR-1ST-PH	✓	PHENOLIC		350#
4SBR-1ST-PH-TLB	✓	PHENOLIC	Top Lock Brake	350#

CALL FOR PRICING

3" 1ST - Pop In Casters

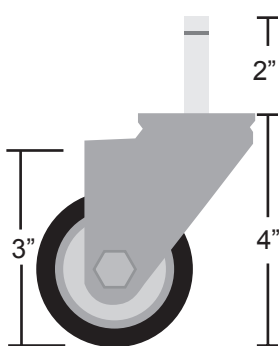

3" Part #	NSF	Wheel Material	Brake	Weight Capacity
3SBR-1ST-PLY	✓	POLYURETHANE		300#
3SBR-1ST-PLY-TLB	✓	POLYURETHANE	Top Lock Brake	300#
3SBR-1ST-HR	✓	HARD RUBBER		300#
3SBR-1ST-HR-TLB	✓	HARD RUBBER	Top Lock Brake	300#
3SBR-1ST-GR	✓	GRAY RUBBER		250#
3SBR-1ST-GR-TLB	✓	GRAY RUBBER	Top Lock Brake	250#
3SBR-1ST-LDP	✓	POLYOLEFIN		300#
3SBR-1ST-LDP-TLB	✓	POLYOLEFIN	Top Lock Brake	300#
3SBR-1ST-PH	✓	PHENOLIC		350#
3SBR-1ST-PH-TLB	✓	PHENOLIC	Top Lock Brake	350#

CALL FOR PRICING